

# installation and maintenance manual

FOR THE INSTALLER AND THE USER

## NESTA CHROME

24·32·38·45 kW

---

WALL – HUNG CONDENSING BOILER

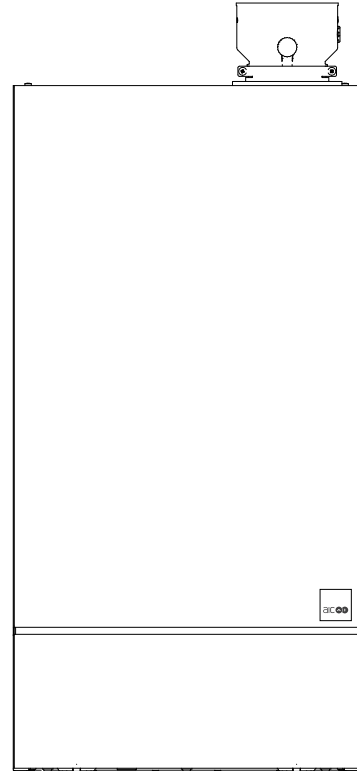

# TABLE OF CONTENTS

<b>GENERAL INFORMATION</b> .....	<b>G-4</b>	AIC-Approved Chimney Components.....	U-46
Liabilities of the Manufacturer, the Installer and the End user.....	G-4	Engineering the Chimney System.....	U-48
About this Manual.....	G-5	Accessories.....	U-48
Safety Instructions.....	G-6	Calculation of the Chimney Length.....	U-48
Package Contents.....	G-7	Equivalent Length of Chimney Components.....	U-48
Boiler Marking.....	G-7	Maximum Chimney Length (terminals incl.).....	U-48
<b>PRODUCT DESCRIPTION</b> .....	<b>G-8</b>	Safety Instructions for the Electrical	
NESTA CHROME 24-32-38-45.....	G-8	Connections.....	U-49
General Description.....	G-8	Cables.....	U-49
Frost Protection.....	G-8	Routing the Cables.....	U-49
Safety Devices.....	G-8	Wiring Diagram.....	U-50
Optional equipment.....	G-8	Accessing the High and Low Voltage Terminal Strips and Electronic Board.....	U-52
Control Panel and Main Functions.....	G-10	<b>COMMISSIONING</b> .....	<b>U-53</b>
Symbols and Messages on the Control Panel ...	G-11	Safety Instructions Before Start-up.....	U-53
<b>TECHNICAL SPECIFICATIONS</b> .....	<b>G-12</b>	Filling the System.....	U-53
Dimensions and Clearances.....	G-12	Start-up and Commissioning.....	U-54
Performance and		Combustion Adjustments (G20/G25/G31).....	U-55
Efficiency Data.....	G-14	Combustion Adjustments (G20Y20).....	U-55
ErP Data.....	G-14	Commissioning Wizard.....	U-56
Combustion Data.....	G-15	Accessing the Commissioning Wizard.....	U-56
Electrical Data.....	G-15	General Structure of the Commissioning Wizard.....	U-57
Gas Data.....	G-16	<b>MAINTENANCE</b> .....	<b>U-60</b>
Gas categories.....	G-16	Safety Instructions for Maintenance.....	U-60
Hydraulic Data.....	G-17	Maintenance Requirements.....	U-61
Pressure Drop Curve.....	G-17	Shutting Down for Maintenance.....	U-62
Flow Rate.....	G-17	Draining the Boiler.....	U-62
<b>INSTRUCTIONS FOR THE USER</b> .....	<b>G-18</b>	Restarting after Maintenance.....	U-62
Safety Instructions for the User.....	G-18	Removing and Installing the Ignition and Ionisation Electrodes.....	U-63
Periodic checks.....	U-19	Removing and Installing the Fan and Air-Gas Mixer Assembly.....	U-64
Starting the Appliance.....	U-20	Removing and Installing the Burner.....	U-66
Stopping the Appliance.....	U-20	Checking and Cleaning the Combustion Chamber.....	U-68
What to Do if... ..	U-20	Checking the Flue Pressure Switch operation..	U-68
Operating the Controller - End User Level.....	U-21	<b>ADDITIONAL INFORMATION FOR THE INSTALLER</b> .....	<b>U-69</b>
Basic Settings.....	U-24	Optional Accessories.....	U-69
Safety Instructions for the Installation.....	U-27	Extension Modules.....	U-69
Handling the Product.....	U-28	Web Server Module.....	U-69
Unpacking the Product.....	U-28	Cascade module.....	U-69
Installing and Preparing the Boiler.....	U-28	Hydraulic kits.....	U-69
Installing the Wall Bracket.....	U-28	Boilers in a Cascade System.....	U-70
Installing and Removing the Condensate Trap ...	U-29	Weather Compensation Curve.....	U-72
Removing and Installing the Front Panel.....	U-30	Boiler Settings for the Installer.....	U-73
Requirements for the Hydraulic Connections.....	U-31	Access Levels.....	U-73
Water Quality Requirements to Prevent		Selecting the User Level & Accessing the Complete	
Scaling and Corrosion.....	U-32	Parameter List.....	U-73
Typical Hydraulic Connections - Heating Circuit..	U-33	Menus and Settings.....	U-73
Hydraulic Connections - Cascaded boilers, with External Domestic Hot Water Tank and Plate Heat Exchanger.....	U-34	Quick access to functions for the Installer.....	U-74
Hydraulic Connections - Cascaded boilers, with External Domestic Hot Water Tank and Low Loss Header.....	U-35	Structure of Menus for the Installer.....	U-75
Safety Instructions for the Gas Connection ...	U-36	Error Codes and Solutions.....	U-78
Conversion to Propane.....	U-37	Performing Reset.....	U-83
Adjustment of Fan Speeds.....	U-38	Troubleshooting.....	U-84
Combustion Adjustment after Gas Conversion ..	U-39	Maintenance Messages.....	U-85
Safety Instructions for the Chimney Connections..	U-41	Installation Checklist.....	U-86
General Instructions for the Installation of		Combustion Parameters - Log Sheet.....	U-89
AIC-approved Chimney Components.....	U-42	Water Parameters - Log Sheet.....	U-90
Chimney Connection.....	U-43	<b>DECLARATION OF CONFORMITY</b> .....	<b>U-91</b>

Fig. 1. Data Plate - Typical.....G-7	Fig. 20. Accessing the Terminal Strip and Electronic Board.....U-52
Fig. 2. Boiler Components .....G-9	Fig. 21. Filling the System - Typical .....U-53
Fig. 3. Control Panel..... G-10	Fig. 22. Combustion Adjustment on Gas Valve .....U-55
Fig. 4. Typical Display..... G-11	Fig. 23. Draining the Boiler - Typical .....U-62
Fig. 5. Single Boiler Clearances..... G-12	Fig. 24. Removing and Installing the Electrodes .....U-63
Fig. 6. Clearances for Cascaded Boilers..... G-12	Fig. 25. Removing and Installing the Fan and Air-Gas Mixer Assembly .....U-65
Fig. 7. Hydraulic pressure drop - N 24 to N 45 WH.....G-17	Fig. 26. Removing and Installing the Burner .....U-67
Fig. 8. Wall bracket Installation .....U-28	Fig. 27. Cleaning the Combustion Chamber .....U-68
Fig. 9. Condensate Trap Installation.....U-29	Fig. 28. Testing the Flue Pressure Switch.....U-68
Fig. 10. Removing/Installing the Access Panels.....U-30	Fig. 29. Extension Module.....U-69
Fig. 11. Typical Heating System .....U-33	Fig. 30. Cascade Module .....U-69
Fig. 12. Cascaded Boilers, with External Domestic Hot Water Tank and Plate Heat Exchanger...U-34	Fig. 31. Web Server Module.....U-69
Fig. 13. Cascaded Boilers, with External Domestic Hot Water Tank and Low Loss Header.....U-35	Fig. 32. Principles of Cascade .....U-70
FIG. 14. NESTA CHROME Gas Valve.....U-36	Fig. 33. Cascading Module.....U-70
Fig. 15. Gas Conversion - Orifice Replacement.....U-37	Fig. 34. Cascade System with Plate Heat Exchanger / Low Loss Header .....U-71
Fig. 16. Fan Speed Adjustment - Typical Screen .....U-38	Fig. 35. Heating Curve Slope .....U-72
Fig. 17. Combustion Adjustment - Control Panel .....U-39	
Fig. 18. Combustion Adjustment on Gas Valve .....U-40	
Fig. 19. Routing the Electrical Cables N 24 WH to N 45 WH .....U-49	

### Appliance Naming

In the documentation, products of the Nesta Chrome range can be designated indifferently using a full name or abbreviated name:

- “Nesta Chrome 24 (N 24 WH)” ► **Nesta Chrome 24** or **N 24 WH**
- “Nesta Chrome 32 (N 32 WH)” ► **Nesta Chrome 32** or **N 32 WH**
- “Nesta Chrome 38 (N 38 WH)” ► **Nesta Chrome 38** or **N 38 WH**
- “Nesta Chrome 45 (N 45 WH)” ► **Nesta Chrome 45** or **N 45 WH**

### Liabilities of the Manufacturer, the Installer and the End user

#### Manufacturer

Our products are manufactured in compliance with the requirements of the applicable European Directives and standards, and are therefore delivered with all the required documentation and markings.

The quality of our products is essential to us, and we aim therefore at improving them continually. To this end, we reserve the right to change the technical characteristics and features of our products without prior notice. Please check for the latest revision of the manual on our website ([www.myaic.eu](http://www.myaic.eu)).

The manufacturer shall not be held liable for any malfunction of the product resulting from:

- › The failure to comply with the safety and installation instructions provided herein,
- › The failure to comply with the safety and operation instructions and recommendations provided herein,
- › The failure to have the appliance maintained regularly,
- › A modification of the appliance that is not approved by the manufacturer,
- › The use the product for any other purpose than its intended use,
- › The use of components and accessories that are not approved by the manufacturer.

#### Installer

The installer is responsible for the correct installation, conversion (as required) and commissioning of the appliance according to:

- › The instructions and recommendations provided herein
- › The applicable regulations and standards

The installer shall provide the end-user with:

- › Any relevant explanation about the operation of the appliance and the heating system as well as the safety devices that are provided,
- › Any instruction regarding periodic checks to be performed and possible anomaly to be reported
- › All the documentation delivered with the appliance and installed accessories.

The installer shall also inform the end-user of the necessity to have the appliance checked and maintained regularly by a qualified professional.

#### End-user

To ensure the best performances and safety of the appliance, the end-user shall:

- › Make sure that the appliance is installed, converted (as required), commissioned and adjusted by a qualified professional,
- › Make sure that the appliance is checked and maintained regularly by a qualified professional,
- › Comply with all the instructions and recommendations provided in the appliance documentation,
- › Make sure to receive from the installer all the necessary explanations related to the operation of the appliance and the safety devices,
- › Make sure to receive from the installer all the appliance and accessories documentation,
- › Keep all the appliance documentation in a safe place for future use.

The end-user shall use the product for its intended use.



- › Should the installer or the end user not comply with the instructions and requirements stated in this manual, the warranty will be void.
- › For more information on the warranty terms and conditions, please connect to our website: [www.myaic.eu](http://www.myaic.eu).

## About this Manual

This documentation is part of the product. It will be handed over to the end-user who will keep it, with all the other applicable documents, in a safe place and readily available for use.

Before installing, operating or maintaining the appliance, please carefully read this manual and all the applicable documents provided with the components and accessories. They contain essential safety information.

### Symbols in this Manual



Indicates an essential instruction which, if not followed, can result in a hazardous situation that can cause serious damage to equipment and/or injuries or death.



Indicates an essential instruction in relation with the presence of electrical power and a danger of electrical shock.



Indicates an important instruction which, if not followed, could result in a hazardous situation that could cause damage to equipment and/or injuries.



Indicates important information.

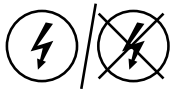

The electrical supply to the appliance must be activated/deactivated through the external circuit breaker or the power supply cable must be connected/disconnected.

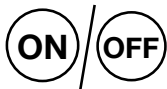

The appliance must be started/stopped using the ON/OFF switch installed on the appliance.



The gas supply to the appliance must be provided/shut down through the external gas tap.



The water circuit of the appliance must be full of water/empty.

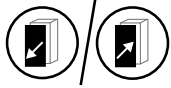

The front and top access panel(s) of the appliance must be removed/installed.



The appliance must have cooled down.



Gas connection.



Heating circuit supply connection.



Heating circuit return connection.

### Symbols on the Appliance



High Voltage - danger of electric shock.



Ground / Earth.



Heating circuit connection.



Gas connection.

For an explanation of the symbols on the control panel, please see “*Symbols and Messages on the Control Panel*” on page G-11.

### Symbols on the Packaging



This side up



Keep dry



Fragile



Do not stack



The prefixes used in the page numbering indicate the following:

**G-** : General information

**U-** : Pages intended for the end user

**I-** : Pages intended exclusively for the qualified professional (e.g. installer)

Safety Instructions



**IF YOU SMELL GAS:**

→ **DO NOT:**

- Use an open flame
- Smoke
- Use electrical devices (phones, doorbell, etc.) or switches

→ **DO:**

- Close the gas supply
- Open all doors and windows to ventilate the room
- Inform the neighbours of the danger by knocking at the doors.
- Get out of the building
- Call the gas company



- This product is intended as a heat generator for heating systems.
- This appliance must be installed according to the applicable local regulations and standards.
- This appliance can be used by children who are at least 8 years old and by persons with reduced physical, sensory or mental capabilities or lack of experience and knowledge, provided that they are under supervision or have been given instructions concerning the use of the appliance in a safe way and that they understand the hazards involved.
- Cleaning and user maintenance shall not be performed by children without supervision. Children shall not play with the appliance.
- Any modification to the appliance and its components is strictly forbidden without the prior written consent of the manufacturer.
- If components need to be replaced, only genuine factory parts or components approved by the manufacturer must be used.



- When working on the appliance and the system, make sure to use the appropriate tools to avoid damaging the pipes and components.
- If works need to be performed close to the appliance (e.g. in the boiler room or close to the air inlets), make sure to shut down the appliance to prevent dust from entering and accumulating in the appliance.
- The appliance contains a frost-protection feature that will protect the appliance against frost, provided that the appliance remains in operation and the radiator valves are open.



- *When unpacking the appliance, check the integrity and condition of the packaging and that all the components and accessories described in the packing list are present. Contact your supplier in case of problem.*
- *When discarding the packaging, do not contaminate the environment. Dispose of it according to the applicable local regulations on recycling.*

## Package Contents

- ▶ A NESTA CHROME boiler
- ▶ An Installation and Maintenance manual
- ▶ A bracket and hardware for wall installation
- ▶ A condensate trap (syphon), to be installed
- ▶ A gas conversion kit

Refer to **“Unpacking the Product” on page U-28** for the complete unpacking and installation instructions.

## Boiler Marking

The data plate is located at the bottom of the boiler.

In addition, the S/N and appliance type are also available on a sticker placed inside the front face flap to make the information easily available if technical support is needed.



Fig. 1. Data Plate - Typical

Symbol	Description
	Electrical data
	<b>PMS</b> maximum operating pressure
	<b>Tmax</b> maximum primary temperature
	<b>V</b> water content
	<b>PMS</b> maximum operating pressure (DHW circuit)
	<b>Tmax</b> maximum DHW temperature
	<b>V</b> water content
	Chimney types
	NOx class

Symbol	Description
<b>Qmin</b>	Minimum heat input
<b>Qn</b>	Nominal heat input
<b>Pmin (80/60°C)</b>	Minimum heat output (80/60°C)
<b>Pn (80/60°C)</b>	Nominal heat output (80/60°C)
<b>Pmin (50/30°C)</b>	Minimum heat output (50/30°C)
<b>Pn (50/30°C)</b>	Nominal heat output (50/30°C)
	CE sign for the compliance of the device with CE directives
	Note about handling waste electronic equipment



The use of symbols on the data plate depends on the type of product.

## PRODUCT DESCRIPTION

### NESTA CHROME 24-32-38-45

#### General Description

This wall-hung series of NESTA CHROME boilers consists of compact, low-emission condensing appliances with a pre-mix burner, a stainless steel heat exchanger and a lightweight casing.

The fully radial burner ensures a high modulation ratio, combustion stability and very low NOx emissions.

The unique and proven “fire-tube” heat exchanger offers a large heat exchange surface to optimise energy and heating efficiency.

The NESTA CHROME series is designed for heating systems and can be used for Domestic Hot Water production (provided that the system contains an optional external tank).

The appliances are built for natural gas but can be converted to operate with liquefied gas (propane), by changing the gas valve orifice and performing additional setup. The gas conversion process must take place before commissioning and comply with applicable local regulations and standards.

NESTA CHROME boilers are able to control 3 heating circuits with mixing functions, through 3 optional extension modules. Each extension module requires a power supply and a bus connection. Refer to **“Optional Accessories” on page U-69** for more information.

The appliance **is not** provided with a built-in circulating pump. Therefore, the system must be equipped with at least one pump for standard system set up.

NESTA CHROME boilers can be connected in a cascade configuration, which means that the boilers are connected to the same water circuit and electronic controller, with one boiler operating as the “Principal”, and the others as “subsequent”. Refer to **“Boilers in a Cascade System” on page U-70** for more information on cascade system possibilities.

#### Frost Protection

The NESTA CHROME boilers have a built-in anti-frost protection. The pump and the burner are started as required when the return water temperature drops below 5°C (as measured by the boiler internal sensor installed on the return circuit).

The pump and/or burner will turn off when the return temperature reaches the required setpoint.

The anti-frost protection function only protects the boiler, not the entire system.

#### Safety Devices

The NESTA CHROME boilers are equipped with a series of sensors and switches that provide safety for your appliance and heating system, such as:

- Water circuit temperature sensors (supply, return, system, etc.)
- Gas pressure switch
- Flue pressure switch
- Water pressure sensor
- Flue temperature sensor
- Alarm contacts

The NESTA CHROME boilers **are not** provided with the following mandatory safety equipment that the installer must place in the system:

- Expansion tank, suitable for the system size
- Safety group, composed of a safety valve (pressure rating adapted to the system), an automatic relief valve and a manometer
- Air relief valve(s), at the high point(s) of the system

#### Optional equipment

Some optional equipment can be used with the NESTA CHROME boilers. Please contact your AIC representative for more information and a list of available equipment.

To lengthen the life of your boiler and heating system, in addition to the recommended water characteristics described in **“Water Quality Requirements to Prevent Scaling and Corrosion” on page U-32**, the following equipment can be installed in the heating circuit:

- Water filter / dirt separator
- Air separator
- Low loss header
- Plate heat exchanger

See **“Requirements for the Hydraulic Connections” on page U-31** for more information on this equipment.





Fig. 2. Boiler Components

**KEY**

- |   |   |
|---|---|
| 1. Concentric chimney connection (Ø 80/125 mm)                          | 11. On-Off switch                               |
| 2. Gas valve, with throttle and offset screws for combustion adjustment | 12. Condensate trap                             |
| 3. Stainless steel "fire tube" heat exchanger                           | 13. Heating supply pipe                         |
| 4. Gas pipe   | 14. Ionisation electrode                        |
| 5. Flue exhaust pipe with temperature sensor                            | 15. Flame sight glass                           |
| 6. Stainless steel condens dish   | 16. Air vent                                    |
| 7. Flue pressure switch   | 17. Ignition transformer                        |
| 8. Heating return with temperature sensor                               | 18. Burner assembly, with fan and air-gas mixer |
| 9. Electronic junction box (incl. boiler management unit - not shown)   | 19. Gas pressure switch                         |
| 10. Control panel with LCD display                                      | 20. Air inlet to air-gas mixer                  |

Control Panel and Main Functions

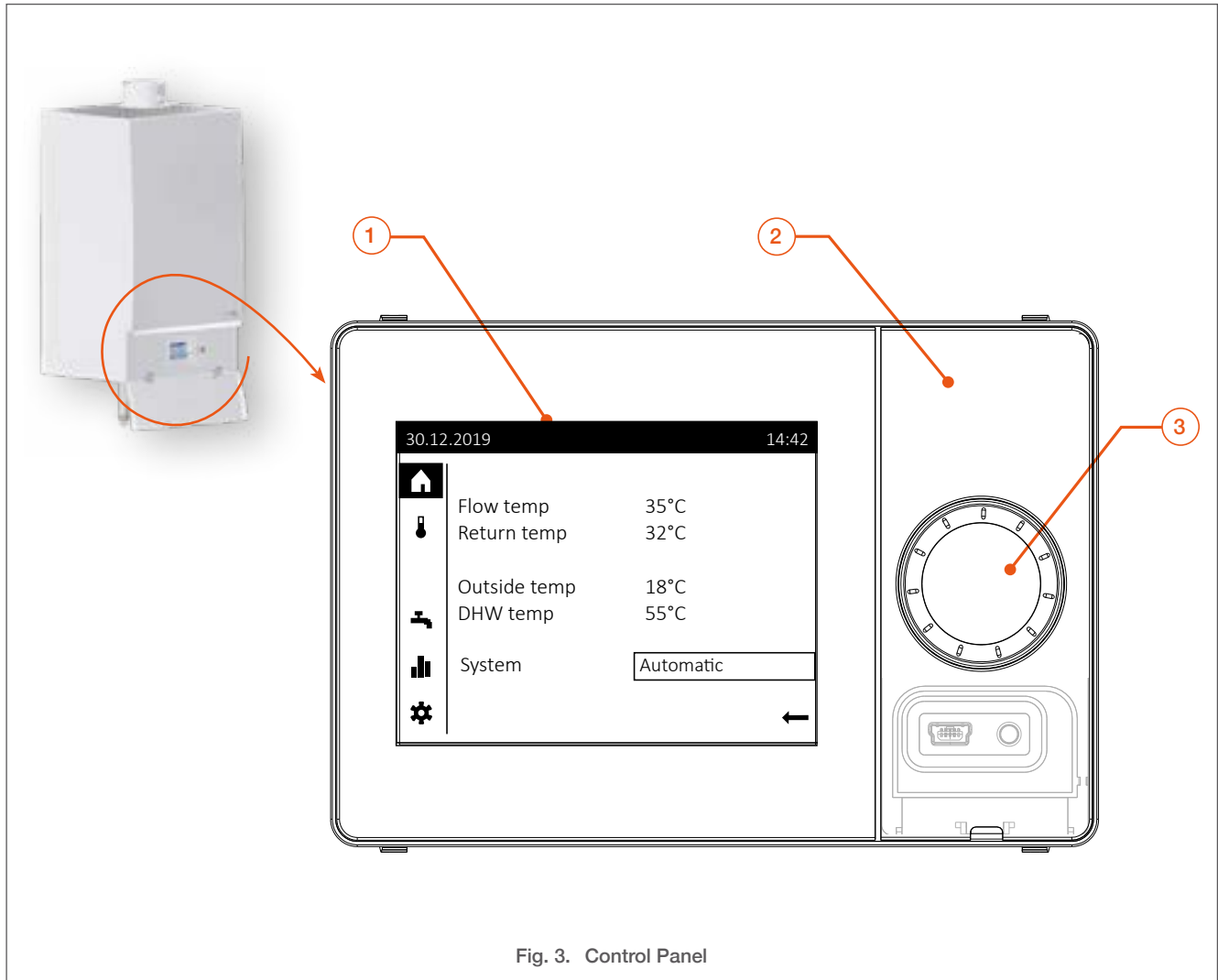

Fig. 3. Control Panel

KEY

1. **LCD Display** - The display illuminates whenever the rotary selector is rotated or depressed, and remains on for 8 minutes. For a detail of the symbols and messages displayed on the screen, see **“Symbols and Messages on the Control Panel”** on page G-11.
2. **Removable panel** - To access the USB connector and Reset button located underneath (showed in light grey on the picture, for information).
3. **Rotary selector** - It can be used in 3 different ways:
  - ▶ Turning the selector to the left or to the right allows to scroll through the menus (icons/functions) or increase/decrease a value after selecting a function.



*When entering a menu/sub-menu, the slow rotation of the selector to the right (clockwise) allows to scroll through the menu, down to the last function. Turning the selector to the left (counter-clockwise) allows to scroll up to the first function of the menu.*

- ▶ Depressing the selector (short push) allows to select a function/value and validate a choice.
- ▶ Depressing the selector for more than 3 sec. when an error is displayed on the screen, takes you back to the Home screen. Doing the same in Expert menus brings back to the Expert view start page.

For more information on the operation and menus of the controller, see **“Basic Settings”** on page U-24.

## Symbols and Messages on the Control Panel

The control panel display is divided into several zones (See **Fig. 4**):

- ▶ a **vertical menu bar (1)** on the left side of the screen, comprising a series of icons to access various menus. When one of the icon is selected and active, it displays against a black background (2). When one icon is selected and activated by pressing the selector, the menu bar disappears and gives way to the work area.
- ▶ a **horizontal status bar (3)** at the top of the screen. It permanently displays the time and, according to the situation, specific icons (Alarm, Maintenance, Event, Manual adjustment, User level and Producer in operation). See a detail of the symbols below.
- ▶ a **work area (4)**, comprising menu and function-specific information as well as operating mode. It also displays a **back arrow (5)**, allowing to exit the work area and go back to the vertical menu bar.

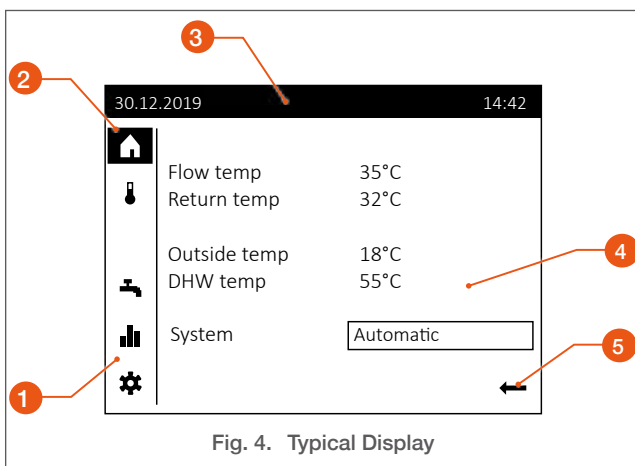









Fig. 4. Typical Display

Symbols of the **vertical menu bar** (some of them will appear only if the circuit is enabled):

-  **Home.** Gives access to the System status and change it from *automatic* to *off*.
-  **Temperature.** Gives access to the heating functions and setpoints.
-  **Ventilation.** Not used.
-  **Domestic Hot Water.** Gives access to the DHW-related functions.
-  **Information.** Gives access to messages (history, errors, etc.), system information and consumption information.

-  **Service/settings.** Gives access to setting options on device or system, allows to operate special operations (e.g. for maintenance work) and allows to log in, in expert view (access to additional pages for the Installer only).

-  **Diagnostics (Expert only).** Analyze and test info on the system.

-  **Adjust/repair (Expert only).** Allows to adjust the parameters in the 'Complete parameter list', and to access the commissioning wizard.

Symbols appearing in the **horizontal status bar**:

-  **Alarm.** Indicates an error in the system.

-  **Maintenance/Special operations.** It indicates the presence of a maintenance message or special operation feedback.

-  **Manual mode.** Indicates that the operating modes on the topic pages are set to manual.

-  **User type.** This symbol with number 1, 2 or 3 indicates the access level:

- 1 - End user/commissioning
- 2 - Heating engineer/installer
- 3 - OEM

-  **Producer.** This symbol indicates the main producer (e.g. oil/gas boiler, heat pump) that is currently switched on.

Symbols and indications in the **work area**:

 Selected item (text or icon)

 Activated item (text or icon)

**Back** To go back to higher level in the menu

 To return to the vertical menu bar icons

Symbols used in the manual to illustrate the **operation of the selector**:

 turn the selector to the left or to the right

 depress shortly the rotary selector

 depress the rotary selector for more than 3 seconds.

# TECHNICAL SPECIFICATIONS

## Dimensions and Clearances

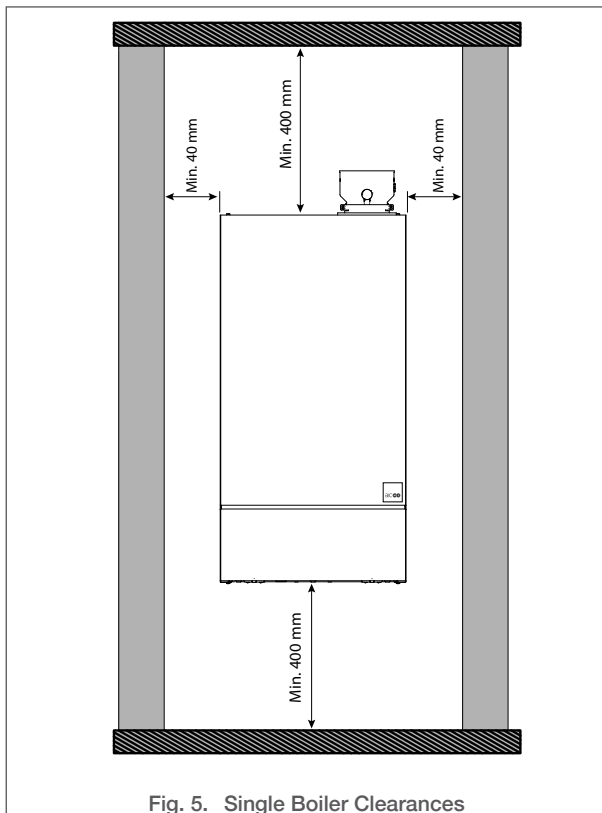
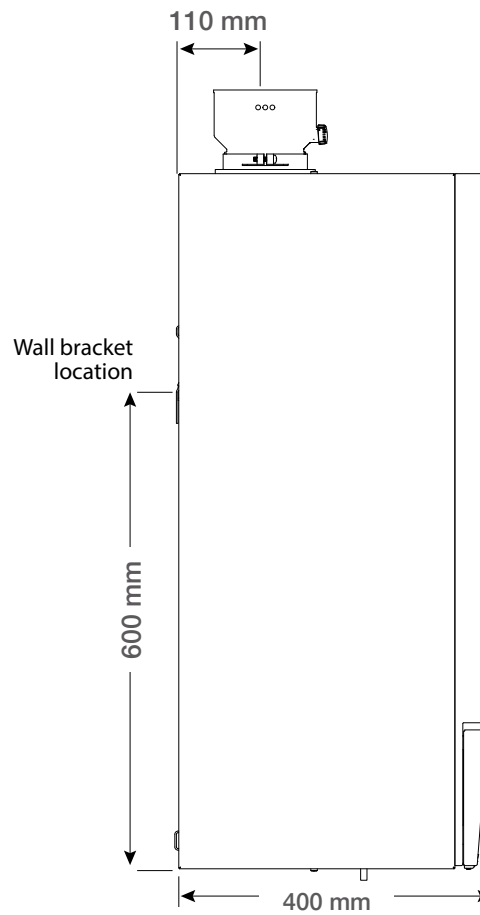
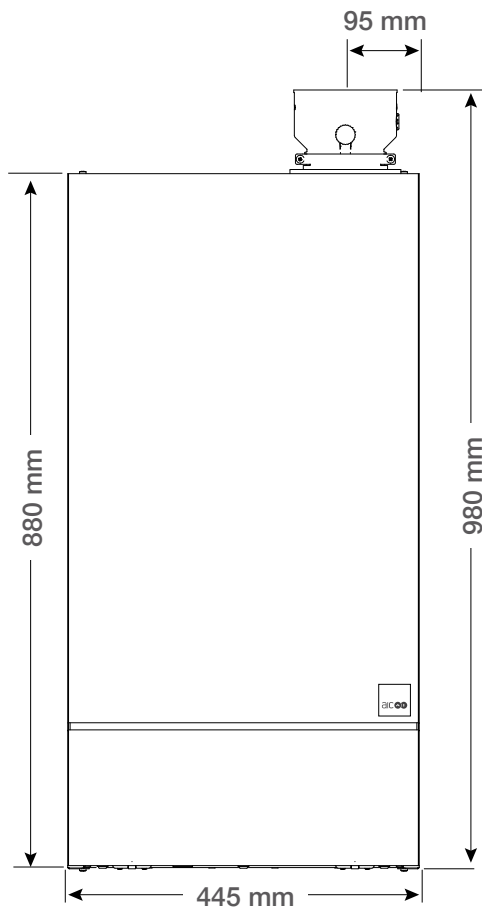

Fig. 5. Single Boiler Clearances

Clearances		Min.	Recommended
top	mm	400	1,000
bottom	mm	400	700
front	mm	700	1,000
sides	mm	40*	

top mm 400 1,000

bottom mm 400 700

front mm 700 1,000

sides mm 40\*

\* In a cascade configuration, boilers can be installed side-by-side with a 40 mm clearance between them.

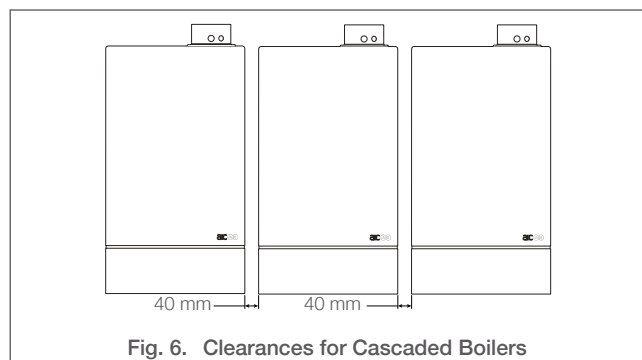
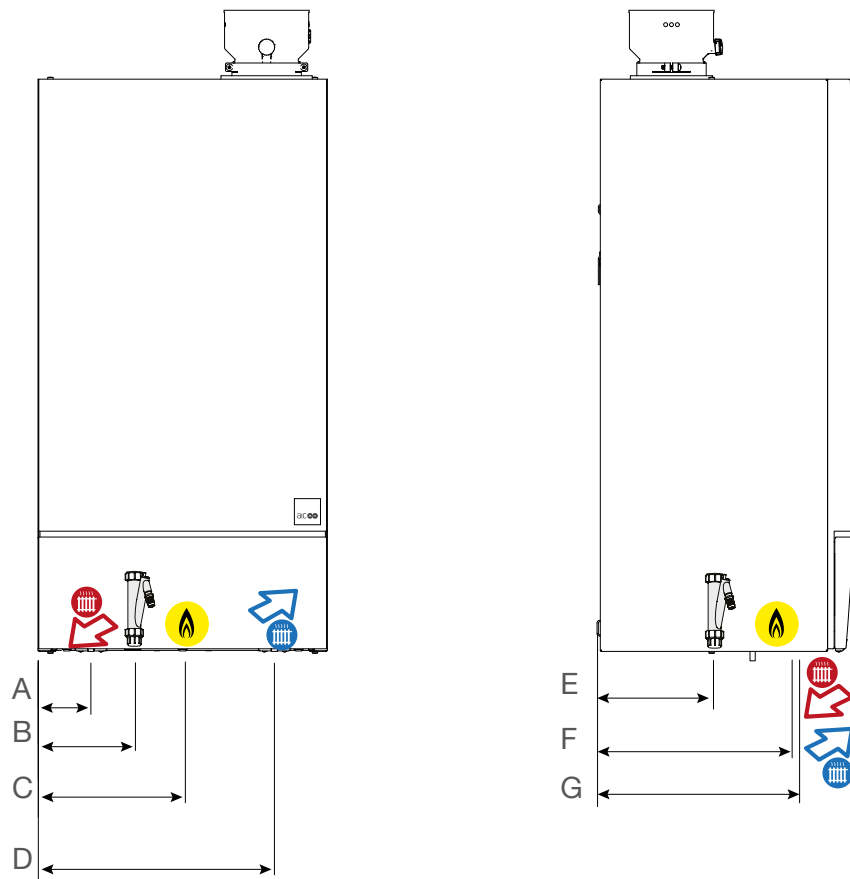

Fig. 6. Clearances for Cascaded Boilers



		N 24 WH	N 32 WH	N 38 WH	N 45 WH
A	mm		47		
B	mm		145		
C	mm		257		
D	mm		329		
E	mm		179		
F	mm		286		
G	mm		288		

		N 24 WH	N 32 WH	N 38 WH	N 45 WH
dry weight	kg		53		64
connections (Ø)					
supply/return (M)	in.		3/4		1
gas (M)	in.			3/4	
chimney	mm		80/125		

## TECHNICAL SPECIFICATIONS

### Performance and Efficiency Data

			<b>N 24 WH</b> (min. - max.)*	<b>N 32 WH</b> (min. - max.)*	<b>N 38 WH</b> (min. - max.)*	<b>N 45 WH</b> (min. - max.)*
heat input (net)	G20/G25/G31	kW	3,2 - 24,0	3,2 - 32,0	4,5 - 38,0	4,5 - 45,0
	G20Y20		3,0 - 22,7	3,0 - 30,3	4,3 - 36,0	4,3 - 42,6
heat output at 80/60°C	G20/G25/G31	kW	3,1 - 23,3	3,1 - 31,1	4,4 - 37,0	4,4 - 43,8
heat output at 50/30°C	G20/G25/G31	kW	3,4 - 25,4	3,4 - 33,8	4,8 - 40,2	4,8 - 47,5
heating efficiency 80/60°C	G20/G25/G31	%	97,0	97,0	97,3	97,3
heating efficiency 50/30°C	G20/G25/G31	%	105,9	105,7	105,7	105,6
useful efficiency at 30% (return at 30°C)		%	108,4	108,4	107,7	107,7
seasonal efficiency		%	93	93	93	93

\* "min. - max." stands for "@Min output" and "@Max output"

### ErP Data

<b>boiler type and model</b>			<b>N 24 WH</b>	<b>N 32 WH</b>	<b>N 38 WH</b>	<b>N 45 WH</b>
condensing boiler	Y/N		Y	Y	Y	Y
low temp boiler	Y/N		Y	Y	Y	Y
combination heater	Y/N		N	N	N	N
<b>useful heat output</b>						
at 30% of rated heat output ( $P_1$ )	kW		7,8	10,4	12,3	14,5
at rated output and high-temp regime ( $P_4$ )	kW		23,3	31,1	37,0	43,8
<b>useful efficiency</b>						
at 30% of rated heat output ( $\eta_1$ )	%		97,6	97,6	97,0	97,0
at rated output and high-temp regime ( $\eta_4$ )	%		87,3	87,3	87,6	87,6
<b>auxiliary electricity consumption</b>						
at full load ( $e_{lmax}$ )	kW		0,0675	0,0675	0,09	0,09
at part load ( $e_{lmin}$ )	kW		0,016	0,016	0,0455	0,0455
in standby mode ( $P_{SB}$ )	kW		0,0028	0,0028	0,0033	0,0033
standby heat loss ( $P_{stby}$ )	kW		0,05	0,05	0,055	0,055
annual energy consumption for space heating	kWh		11 428	14 760	18 018	20 950
sound power level indoors LWA	dB		57	58	60	61
seasonal space heating energy efficiency class				A		

Combustion Data		N 24 WH (min. - max.)*	N 32 WH (min. - max.)*	N 38 WH (min. - max.)*	N 45 WH (min. - max.)*
chimney type(s)		B23, B23P, C13(x), C33(x), C43(x), C53(x), C63(x), C83(x), C93(x)			
flue gas temperature at 80/60°C	°C	60-67	60-67	60-67	60-67
flue gas temperature at 50/30°C	°C	30-51	30-51	30-51	30-51
overheat flue gas temperature	°C	110			
max. flue gas pressure (incl. max wind condition)	Pa	160		210	
Max. chimney length (80/125)	m	15		15	
mass flow rate of flue gases	g/s	1,47 - 10,33	1,47 - 13,98	2,1 - 16,64	2,1 - 19,7
max. condensate volume	kg/h	2,9	3,9	4,6	5,5
CO emissions	mg/kWh	25	31	43	57
CO <sub>2</sub> contents (G20)	%	8,7-9,3±0,2	8,7-9,1±0,1	8,6-9,1±0,2	8,6-9,1±0,2
CO <sub>2</sub> contents (G25)	%	8,7-9,3±0,2	8,7-9,3±0,2	8,5-9,1±0,2	8,5-9,1±0,2
CO <sub>2</sub> contents (G31)	%	10,3-10,9±0,2	10,3-10,9±0,2	10,4-10,9±0,2	10,4-10,9±0,2
O <sub>2</sub> contents (G20/G20Y20)	%	5,4-4,3±0,3	5,4-4,6±0,15	5,5-4,6±0,3	5,5-4,6±0,3
O <sub>2</sub> contents (G25)	%	5,1-4,0±0,3	5,1-4,0±0,3	5,5-4,4±0,3	5,5-4,4±0,3
O <sub>2</sub> contents (G31)	%	5,2-4,3±0,25	5,2-4,3±0,25	5,0-4,3±0,3	5,0-4,3±0,3
NOx level (weighted)	mg/kWh	35,1	35,1	37,6	37,6
NOx class		6			
Fan speeds	rpm	G20/ G20Y20/ G25/G31 Refer to <b>“Adjustment of Fan Speeds”</b> on page U-38.			
Ignition fan speed	rpm	G20/ G20Y20/ G25/G31 3300		2700	

\* “min. - max.” stands for “@Min output” and “@Max output”

Electrical Data		N 24 WH	N 32 WH	N 38 WH	N 45 WH
supply voltage / frequency / current	V / Hz / A	230 / 50 / 6			
protection class	IP	X4D			

# TECHNICAL SPECIFICATIONS

Gas Data		N 24 WH (min. - max.)**	N 32 WH (min. - max.)**	N 38 WH (min. - max.)**	N 45 WH (min. - max.)**	
gas type(s)		G20 - G20Y20 - G25 - G25.3 - G31				
gas categories***		I2E(S,R), I2H, I2E, I2ELL, I2EK, I3P, I12E3P, I12EK3P, I12L3P, I12H3P, I12Er3P				
gas pressure	G20/G20Y20 (20 mbar)	mbar	17-25			
	G25 (25 mbar)	mbar	20-30			
	G25.3 (25 mbar)	mbar	18-33			
	G31 (30/37/50 mbar)	mbar	25-35 / 25-45 / 42,5-57,5			
gas flow rate (G20)*		m <sup>3</sup> /h	0,34 - 2,54	0,34 - 3,37	0,47 - 4,01	0,47 - 4,75
gas flow rate (G25)*		m <sup>3</sup> /h	0,38 - 2,87	0,38 - 3,84	0,54 - 4,54	0,54 - 5,37
gas flow rate (G31)*		m <sup>3</sup> /h	0,13 - 0,96	0,13 - 1,29	0,18 - 1,53	0,18 - 1,81

\* 15°C, 1013.25 mbar, dry gas

\*\* "min. - max." stands for "@Min output" and "@Max output"

\*\*\* Gas categories I2E and I2H can operate with G20Y20 gas type

Gas categories	Gas type	Pressure (mbar)	Country of destination
I2E(S,R)	G20	20	BE
I2H	G20	20	AT, CH, CZ, DK, EE, ES, FI, GB, GR, HR, HU, IE, IT, LT, LV, NO, PT, RO, SE, SI, SK, TR
I2E	G20	20	DE, PL, RO
I2ELL*	G25	20	DE
I2EK*	G20/G25.3	25	NL
I3P	G31	30/37/50	AT, BE, CH, CZ, ES, FR, GB, GR, HR, HU, IE, IT, LT, NL, PL, PT, SL, SK, RO, TR
I12E3P	G20/G31	20/37	PL
I12EK3P*	G20/G25.3/G31	20/25/37	NL
		20/25/37	FR
		25/30	RO
I12L3P	G25/G31	20/30	CZ, FI, RO
		20/37	CH, CZ, GR, HR, IT, LT, SI, SK, TR
		20/50	AT, CH, CZ, SK
I12Er3P	G20/G25/G31	20/25/37/50	FR



Appliances operating with gas categories I2E and I2H can also operate with G20Y20 gas type (G20 natural gas + 20% Hydrogen). Please check your applicable local regulations for compliance before any installation.



Hydraulic Data

		N 24 WH	N 32 WH	N 38 WH	N 45 WH
water content	l	8,0	8,0	11,5	11,6
pressure drop at $\Delta T = 20k$	mbar	< 40 mbar			
minimum operating pressure	bar	0,6			
maximum operating pressure	bar	6			
maximum boiler temperature	$^{\circ}C$	85			

Pressure Drop Curve

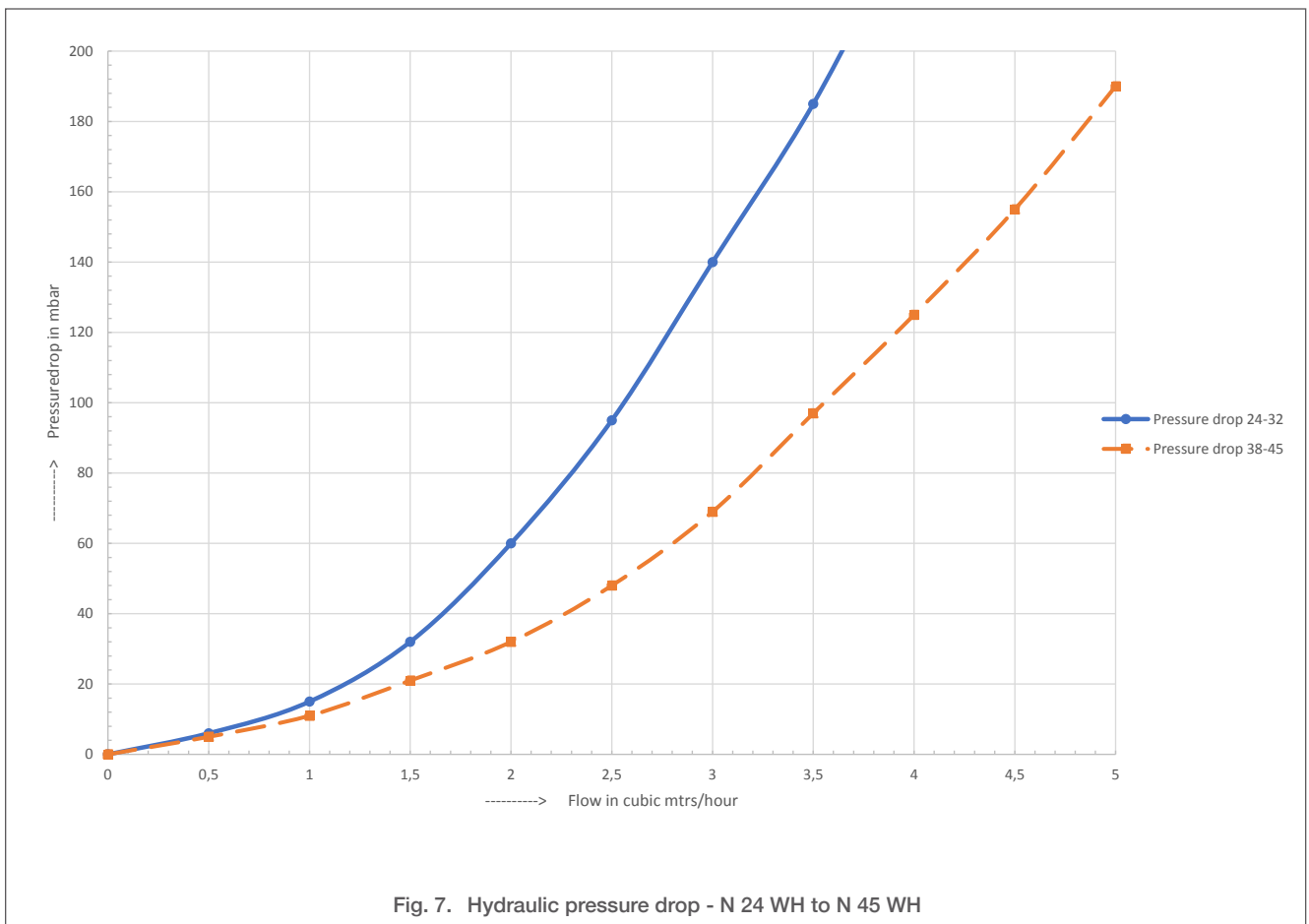

Flow Rate

		N 24 WH	N 32 WH	N 38 WH	N 45 WH
minimum water flow rate at $\Delta T = 20k$	l/min	17	23	27	32

Safety Instructions for the User



**IF YOU SMELL GAS:**

→ **DO NOT:**

- › Use an open flame
- › Smoke
- › Use electrical devices (phones, doorbells, etc.) or switches

→ **DO:**

- › Close the gas supply
- › Open all doors and windows to ventilate the room
- › Inform your neighbours of the danger by knocking at the doors.
- › Get out of the building
- › Call your installer or gas company



- › This appliance can be used by children who are at least 8 years old and by persons with reduced physical, sensory or mental capabilities or lack of experience and knowledge, provided that they are under supervision or have been given instructions concerning the use of the appliance in a safe way and that they understand the hazards involved.
- › Cleaning and user maintenance shall not be performed by children without supervision. Children shall not play with the appliance.
- › For safety reasons, we recommend that smoke and carbon monoxide detectors are installed in the living areas of your building according to the applicable local regulations.
- › If smoke is present, shut down the appliance, ventilate the room and exit the building. Then call your installer to investigate and solve the problem.
- › Do not store any flammable, corrosive or explosive products near the appliance.
- › Do not modify or deactivate any component, nor any safety device in the system.
- › Do not operate the appliance when the casing is open.



- › Do not modify any part of the electrical system or access internal components.
- › Do not touch the appliance with any wet body parts when the appliance is supplied with electrical power.



- › Do not modify or block the condensate outlet(s).
- › Do not open any sealed part or component. Failure to comply with this instruction can result in damages and/or injuries.
- › The sight glass can be very hot when the appliance is in operation. Do not touch the sight glass or its immediate surroundings.
- › Make sure that the appliance and the heating system are prevented from freezing.
- › In case of water leakage, disconnect the appliance from the power supply and gas source, turn off the water supply and call a qualified professional.



- If works need to be performed close to the appliance (e.g. in the boiler room or close to the air inlets), make sure that the appliance is shut down to prevent the ingress and accumulation of dust.
- In case of abnormal noises in the system or the appliance, please notify a qualified professional.
- Any setting of the appliance by the end-user using the installer-specific functions, that would cause the appliance to malfunction, could result in damages to the equipment. Only the end-user settings described in this manual are available to the end-user.
- If a condensate neutralisation system is installed, have it checked and cleaned at least once a year.



*When cleaning the appliance cabinet panels, do not use solvents or aggressive/abrasive cleaning agents. Wipe the surfaces using a soft clean cloth, water and soap.*

## Periodic checks



- Check regularly that the water pressure of the system is at least 0,8 bar when cold. If not, top up the system with water as instructed by the installer at appliance installation or call your installer.
- If a topping up of the system is required to maintain the minimum recommended water pressure, always turn the appliance off and only add small quantities of water at a time. If a large amount of cold water is added in a hot appliance, the appliance can be damaged permanently.
- If the system needs to be topped up regularly, there may be a leak in the system. In that case, call your installer.
- Check regularly that there is no water below the appliance. If there is, call your installer
- Check regularly that there is no error code displayed on the control panel screen. Call your installer as required.

## Disposal of the Product at the End of Service Life

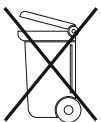

*At the end of service life, the product should not be disposed of as solid urban waste, but should be handed over to a differentiated waste collection centre.*

### Starting the Appliance



The first start-up of the boiler after its installation must be performed by a qualified professional, according to the procedure in “Start-up and Commissioning” on page U-54.

**Conditions:**



**Procedure:**

1. Make sure that the power supply cable is connected to the boiler.
2. Press the On/Off switch located on the right side of the control panel.



When in the ON position, the switch remains illuminated.

3. Select the heating mode as required.
4. Activate the DHW mode as required.

**Follow-on tasks:**

Check the pressure of the circuit in operation. It should be between 1.2 and 6 bar (with pump on).

### Stopping the Appliance

**Conditions:**

None

**Procedure:**

1. Press the On/Off switch located on the right side of the control panel.



When in the OFF position, the switch internal light comes out.

2. To completely cut the power supply to the boiler, either disconnect the power supply cable from the boiler, or use the external circuit breaker.

**Follow-on tasks:**

None

What to Do if...	Cause	Action
Boiler does not start	No power supply	<ol style="list-style-type: none"> <li>1. Check that the power button is in ON position (illuminated).</li> <li>2. Make sure the power supply is connected to the mains.</li> <li>3. Check the external power supply box (circuit breaker) and reset it as required.</li> </ol>
Error code 133 displayed	Time out for flame ignition	<ol style="list-style-type: none"> <li>1. Open controller removable panel and depress Reset button. Refer to “Control Panel and Main Functions” on page G-10</li> <li>2. If the fault appears several times, call your installer.</li> </ol>
Error code 111 displayed	Temperature limit switch open	Check that radiator valves are open/that there is flow across the boiler.
Error code 105 displayed Maintenance icon (🔧)	Maintenance message	Select the Information icon (ℹ️) for details. Refer to “Symbols and Messages on the Control Panel” on page G-11.
Error code 118 displayed	Low water pressure	Refill the heating system.



To remove an error code from the display temporarily and go back to the Home screen, depress the rotary selector for more than 3 seconds.

Operating the Controller - End User Level

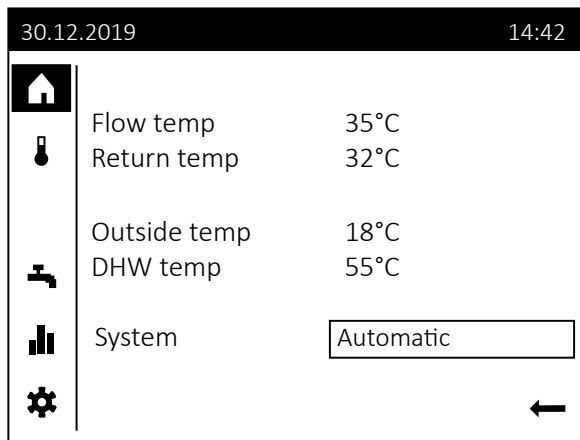



Some icons and parameters are only visible if the circuit is installed and enabled.

Icons	In the work area	Selectable/ Adjustable Parameters	Remark	
	<p><b>Home</b></p> <p>Boiler temp: ---°C</p> <p>Outside temp: ---°C</p> <p>DHW temp : --°C</p>	—	<p>These items indicate the current temperatures, as detected by the system sensors</p>	
	<p>▶ System</p>	<ul style="list-style-type: none"> <li>• Off</li> <li>• Automatic</li> </ul>		<p>In the 'Off' position, the plant or zones are switched off. Energy consumption is reduced to a minimum. The building or zones remain, however, protected (e.g. in protection mode)</p>
	<p>▶ Operating mode</p>	<ul style="list-style-type: none"> <li>• Protection</li> <li>• Automatic</li> <li>• Reduced</li> <li>• Comfort</li> </ul>		<p>In "Protection", the system operates in frost protection mode.</p>
	<p>▶ Temporary</p>	<ul style="list-style-type: none"> <li>• Warmer</li> <li>• ...</li> <li>• Cooler</li> </ul>	<p>In Automatic, the system is operated as per the time switch program, or energy savings functions (e.g. summer/winter mode).</p> <p>Temporary temperature adjustment and time program are available exclusively to the Automatic operating mode. Setting "..." disables the function.</p>	
	<p>▶ Comfort setpoint</p>	<ul style="list-style-type: none"> <li>• 20°C</li> </ul>		
	<p>▶ Time program</p>	<ul style="list-style-type: none"> <li>• Monday</li> <li>• Tuesday</li> <li>• ...</li> <li>• Sunday</li> </ul>	<p>Clock to be setup from 00 to 24 (default: 06:00 to 22:00). Up to 3 phases of heating per day can be set per zone.</p>	



To display the information through this function, make sure that at least one heating circuit is activated (Pgm 5710, "On").

# INSTRUCTIONS FOR THE USER

Icons	In the work area	Selectable/ Adjustable Parameters	Remark
 <b>DHW temp. setting</b>	▶ Operating mode	<ul style="list-style-type: none"> <li>• Off</li> <li>• On</li> </ul>	When “off”, Hot water heating is switched off; when “On”, Hot water is heated to the nominal setpoint as per time program
	▶ Temporary	<ul style="list-style-type: none"> <li>• ...</li> <li>• Recharging</li> </ul>	“Recharging” is used to bring the storage tank to the nominal setpoint when there was a high consumption. “...” deactivates the function.
	▶ Nominal setpoint	<ul style="list-style-type: none"> <li>• 60°C</li> </ul>	
	▶ Time program	—	Active if operating mode is set to “On”.
 <b>Info</b>	▶ Error (error code and description)	—	
	▶ Maintenance (maintenance code and description)	—	
	Boiler ▶ Boiler Temp ... °C ▶ Water pressure ... 0bar	—	
	Heating zone 1 ▶ Off ▶ Room temperature ... °C	—	
	Domestic hot water ▶ Charged ▶ DHW temp ... °C	—	
	Outside temp ▶ Outside temp ... °C ▶ Outside temp min ... °C ▶ Outside temp max ... °C	—	
	Customer service ▶ Tel. Number		Can be defined at commissioning



Icons	In the work area	Selectable/ Adjustable Parameters	Remark
 <b>Settings</b>	Regional settings ▶ Regional settings (1/3)	<ul style="list-style-type: none"> <li>• Time 01:00</li> <li>• Date 01.01.2030</li> </ul>	
	▶ Regional settings (2/3)	<ul style="list-style-type: none"> <li>• Start of summertime 25.03</li> <li>• End of summertime 25.10</li> </ul>	
	▶ Regional settings (3/3)	<ul style="list-style-type: none"> <li>• Language</li> </ul>	(English - Deutsch - Français - Italiano - Nederlands - Español - Portuguese - Dansk - Suomi - Svenska - Polski - Slovensky - Český - Slovenščina - русский - Magyar - Ελληνικά - Türkçe - Serbian - Lietuvių)
	Special operations ▶ Special operations (1/3)	<ul style="list-style-type: none"> <li>• Chimney sweep function</li> </ul>	These functions can be set to "On" or "Off".
	▶ Special operations (2/3)	<ul style="list-style-type: none"> <li>• Manual control</li> </ul>	When set to "On", the Chimney Sweep Function remains so for 1 hour, then turns off automatically.
	▶ Special operations (3/3)	<ul style="list-style-type: none"> <li>• Economy mode --</li> </ul>	
	Settings ▶ Heating zone (1/2)	<ul style="list-style-type: none"> <li>• Comfort setpoint 20.0°C</li> <li>• Reduced setpoint 16.0°C</li> <li>• Frost protection setpoint 10.0°C</li> </ul>	The setpoints can be adjusted here, in steps of 0.5°C
	▶ Heating zone (2/2)	<ul style="list-style-type: none"> <li>• Heating curve slope 1.50</li> <li>• Summer/winter heating limit 18.0°C</li> </ul>	Heating curve can be defined when outside temp is used to control the system temperature
	Expert ▶ Select user level	<ul style="list-style-type: none"> <li>• Enduser</li> <li>• Commissioning</li> <li>• Engineer</li> <li>• OEM</li> </ul>	
	▶ Enter password	<ul style="list-style-type: none"> <li>• - - - -</li> </ul>	For OEM access



*In some recently manufactured products, a password may be required to access the Engineer level and the login will be indicated as unsuccessful if you do not enter it. In that case, please contact your AIC representative for more information.*

Basic Settings

Symbols used for the **operation of the selector**:

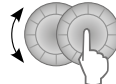
-  turn the selector to the left or to the right.
-  depress shortly the rotary selector.
-  turn the selector to adjust the value, then depress the selector to validate.

1 - Time and Date Adjustment

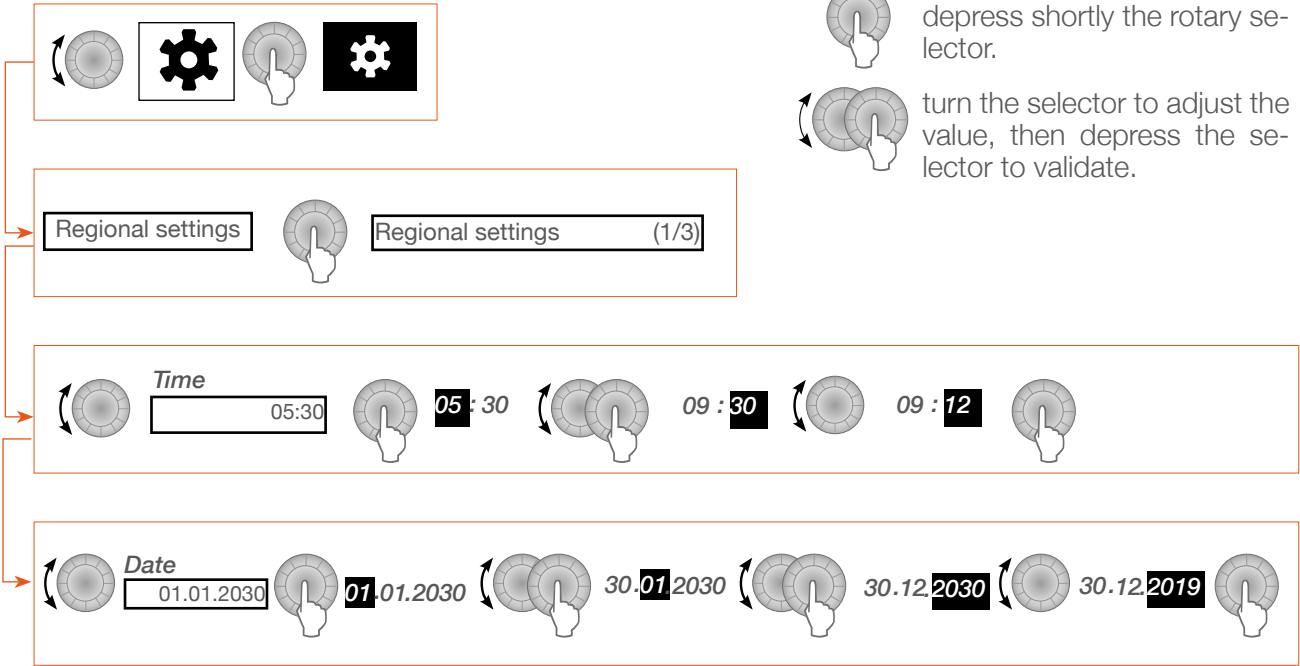

2 - Language Selection

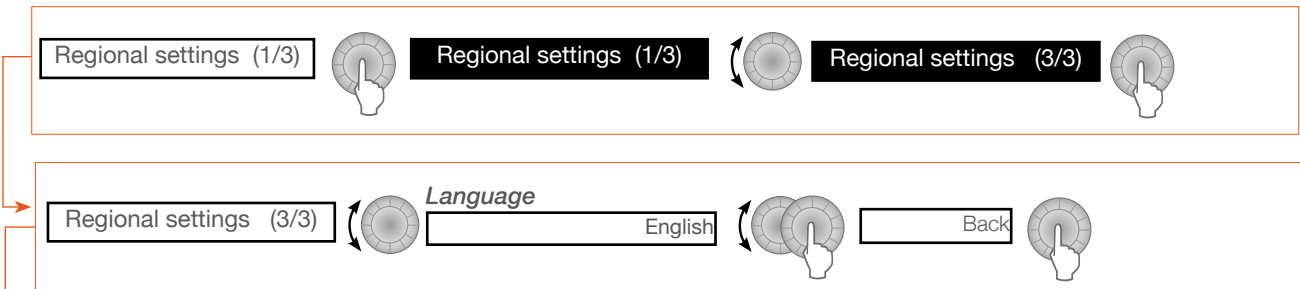

3 - Defining setpoints (Heating)

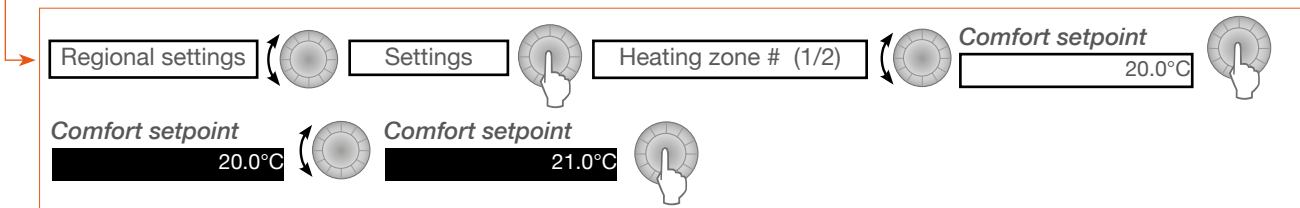

Proceed the same way to adjust “Reduced setpoint” and “Frost protection setpoint”.



4 - Heating Settings - Quick Setup

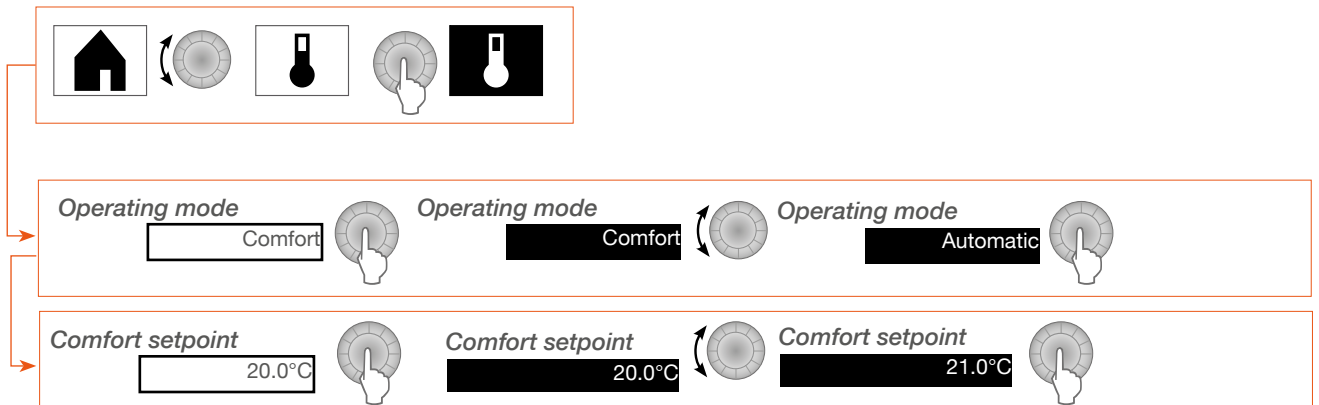

5 - Time Program Definition

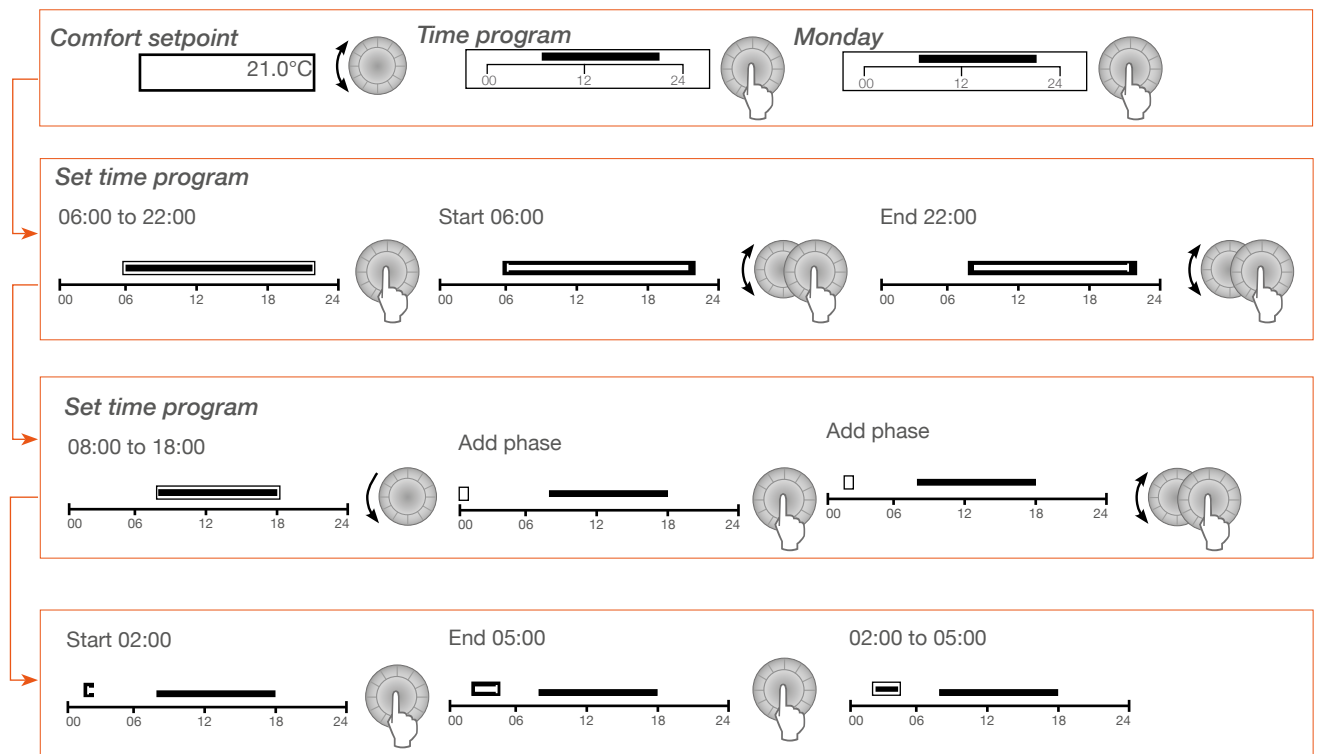

- › Up to 3 phases can be defined per day.
- › The programming process is the same for Heating and Domestic Hot Water circuits.

# INSTRUCTIONS FOR THE USER

## 6 - Accessing System Pressure and Temperatures

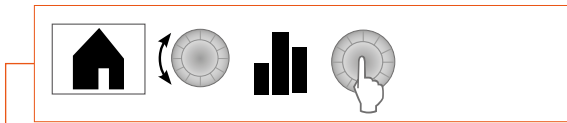

**Error** **Error** **Boiler**

Boiler temp 65°C  
Water pressure 1.2 bar

**Boiler** **Heating zone x**

(Mode) Off/Reduced/Comfort  
Room temperature --°C

**Heating zone x** **DHW**

(Mode) Off/charged  
DHW temp. 60°C

## Safety Instructions for the Installation



- All connections (electrical, flue pipe, hydraulic, gas) must be carried out in accordance with current standards and regulations in force.
- If the appliance is installed against a wall made of heat-sensitive material, such as wood, a suitable insulation must be provided by the installer between the appliance and the wall surface.
- Comply with the clearance dimensions provided in this manual, to prevent any hot part of the appliance from being too close to the walls or any combustible material.
- Make sure to maintain a safe distance of 200 mm from flammable materials; the boiler room may not be used as a storage location for material.
- Do not store any flammable, corrosive or explosive products next to the appliance.
- Do not install the appliance in a location where chemical vapours or dust are present in the ambient or combustion air.
- If the appliance is used on professional premises such as hairdresser's, cleaning company, painter's, etc. where chloride products, solvents, paints, dust, etc. are likely to contaminate the air, make sure to install the appliance in a dedicated boiler room so that the appliance is supplied with clean combustion air.
- Install a condensate neutralisation system according to the applicable local regulations and standards.
- If the appliance is intended to be used with G31 liquefied petroleum gas (propane), installing the appliance below ground level can be hazardous and prohibited in some countries. Please refer to applicable local regulations for installation requirements.



- When the appliance is connected to the electrical network, it must be earthed.
- Make sure that a fuse or circuit breaker of the recommended rating (B10A or according to applicable local regulations) is installed outside the appliance, so as to be able to shut the power down.
- Do not touch the appliance with any wet body parts when it is supplied with electrical power.
- Before performing any operation on the electrical circuit, isolate the electrical supply of the appliance through the external power-cutting device (fuse, circuit breaker, etc.)



- The appliance must be installed in a dry and protected area, with an ambient temperature comprised between 0 and 45°C.
- Make sure to protect the appliance and the water circuit against freezing.
- The appliance must be installed to ensure easy access at all times.
- Use an appropriate means of handling, suitable to the appliance size and weight.
- Floor-standing appliances must be installed on a level base and wall-hung appliances, on a vertically plumb support. Material used for base and support must have sufficient strength to support the appliance weight, water included.
- Make sure that the appliance is installed with a sufficient height to allow the condensates to flow to the sewer, and/or allow the installation of a condensate neutralisation system (as required).
- When lifting, moving or installing the appliance, be careful not to drop it. Once in position, make sure that the appliance is secured.
- Install all pipes and ducts without stress to prevent any leaks from occurring.

# PRODUCT INSTALLATION

## Handling the Product



- ▶ This appliance requires two people to move and handle it, to prevent it from falling. Make sure to comply with applicable local standards and regulations on product handling.
- ▶ It is prohibited to handle the boiler using protruding components or rest the boiler on protruding components.
- ▶ Failure to comply with these recommendations can result in damage to the boiler or injuries to the personnel

Using a hand truck or another person, move the appliance in its packaging close to the installation location.

## Unpacking the Product

The boiler is delivered in a cardboard box:

1. Carefully remove the cardboard packaging and protections.
2. Discard packaging according to applicable local regulations.

## Installing and Preparing the Boiler

1. Install the wall bracket to support the boiler, see procedure opposite and related figure. (See **Fig. 8**).



Make sure to comply with the recommended clearances for the boiler installation, refer to “Dimensions and Clearances” on page G-12.

2. With the help of a second person, install the boiler on the wall bracket and make sure it is secured.

### Follow-on task(s):

1. Install the condensate trap, see “Installing and Removing the Condensate Trap” on page U-29.
2. Perform gas conversion using the optional kit, as required. Please contact your AIC representative.

## Installing the Wall Bracket

### Tools and Material:

- ▶ Pencil
- ▶ Tape measure or equivalent
- ▶ Spirit level or equivalent
- ▶ Power drill and a Ø 10 mm drill bit

### Installation Procedure:

1. Mark reference lines on the wall (centerline, boiler sides).
2. Mark the drilling locations according to the dimensions shown in the figure below. Make sure the marks are level.
3. Drill six holes in the supporting wall.
4. Fasten the bracket to the wall using the hardware provided with the boiler.

### Follow-on task(s):

1. Install the boiler on the wall bracket.

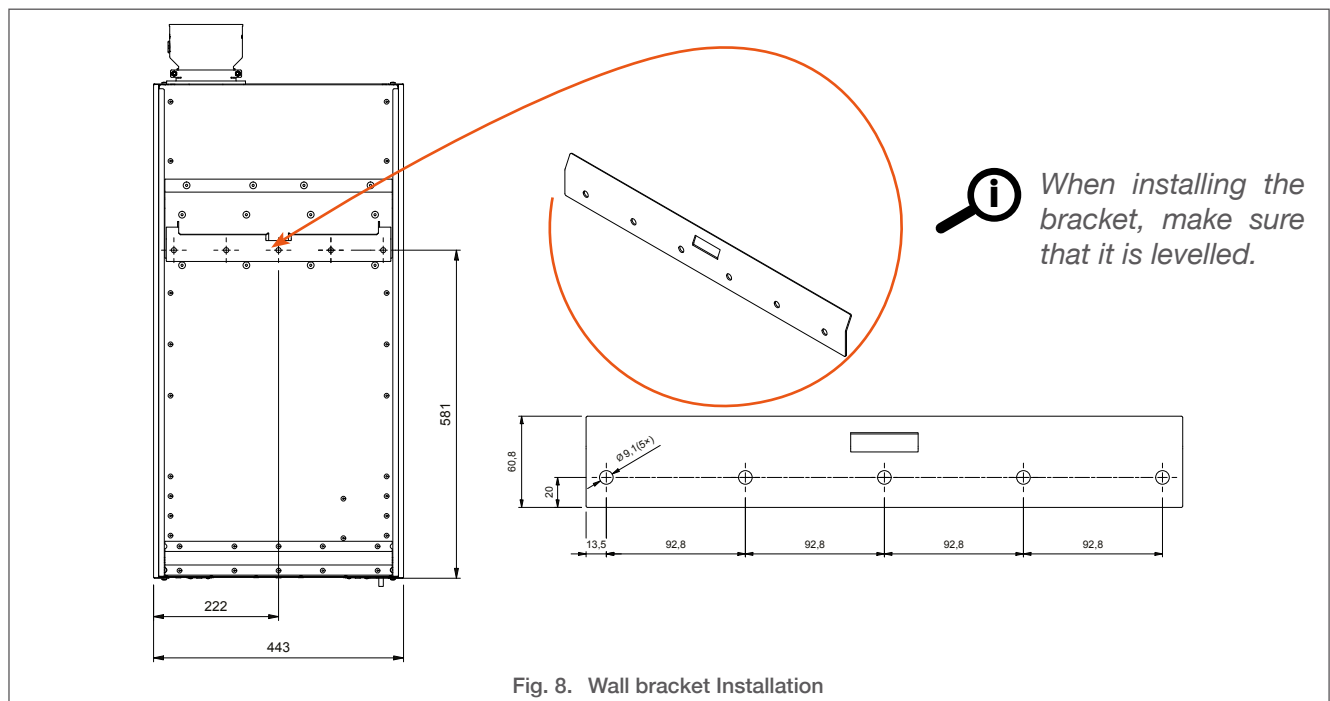

Fig. 8. Wall bracket Installation

## Installing and Removing the Condensate Trap

**Conditions:**  

### Tools and Material:

The following, provided with the boiler:

- Condensate trap
- Clip
- Hose

### First Installation:

1. Install the O-ring (1) on the boiler connection (9), at the bottom of the boiler.
2. Slide the fitting (8) end of the condensate trap body (6) on the boiler connection (9).
3. Insert clip (2) into the fitting (8) to lock the condensate trap in position.
4. Connect the hose to the condensate trap connection (4).
5. Connect the condensate trap hose to a condensate neutralisation system if required, or directly to the drain.

### Removal Procedure for maintenance:

1. Disconnect the hose from the condensate trap connection (4).

2. Holding the condensate trap body (6) with one hand, rotate the locking ring (7) counterclockwise to unlock. Retain ring for reinstallation.
3. Pull the condensate trap body (6) away from the fitting (8).



**At removal, make sure not to lose the condensate trap seal (3) and ball (5), and to retain them for later reinstallation.**

### Installation Procedure after maintenance:

1. Verify that the ball (5) is inside the condensate trap body (6) and install the upper seal (3).



**For correct operation of the condensate trap, make sure that the inner ball and upper seal are installed.**

2. Slide the condensate trap body on the fitting (8).
3. Screw the locking ring (7) to lock in position.
4. Connect the hose to the condensate trap connection (4).

### Follow-on task(s):

1. Before operating the boiler, fill the syphon with water by pouring water into the flue duct.

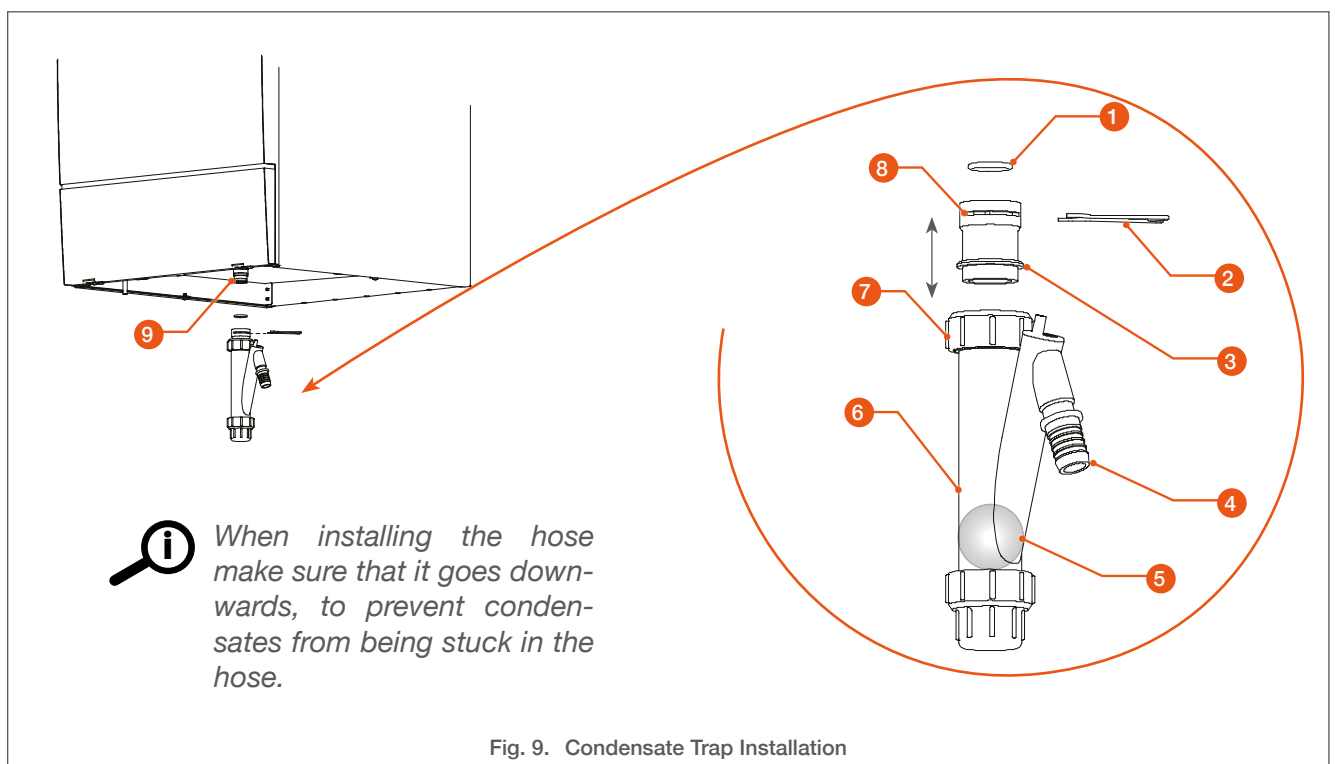

Fig. 9. Condensate Trap Installation

## PRODUCT INSTALLATION

### Removing and Installing the Front Panel

**Conditions:**  

**Tools and Material:**

- › Screwdriver, crosshead

**Removal Procedure:**

1. Remove three bottom screws (1). Retain for reinstallation.
2. Pull the bottom of the front panel, then lift the panel upwards to disengage its upper edge from the top panel groove.

**Installation procedure:**

1. Engage the top of the front panel into the top groove of the boiler frame.
2. Push the bottom of the front panel down towards the boiler frame
3. Install three retained screws (1) at the bottom of the boiler frame.

**Follow-on task(s):**

None

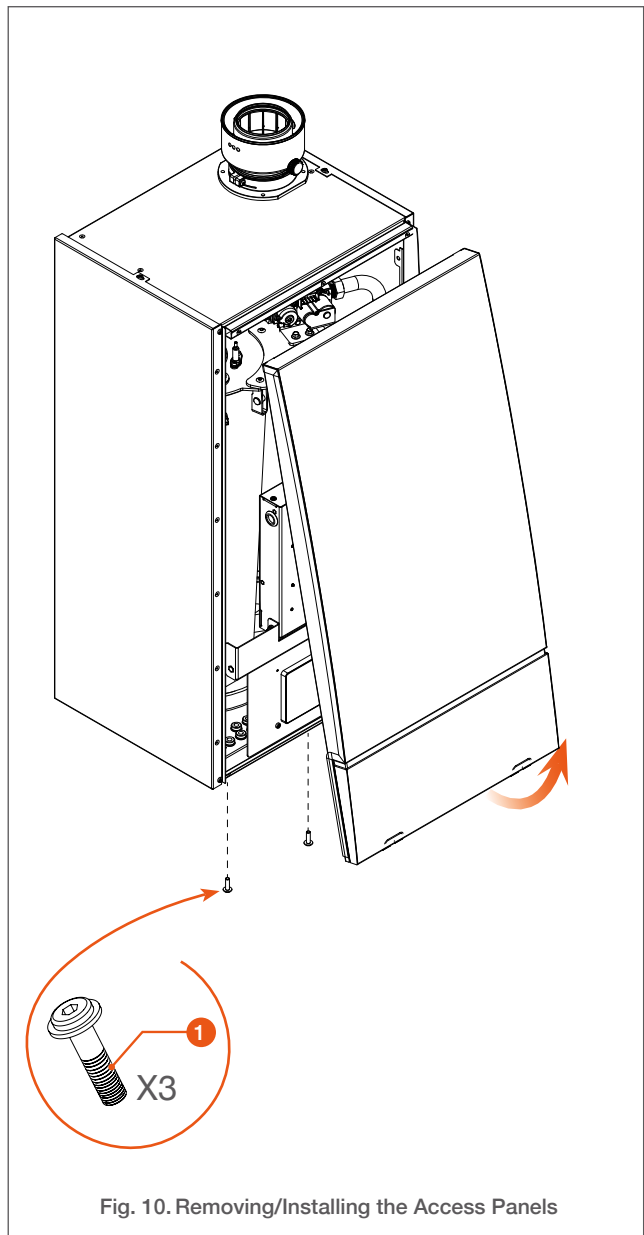

Fig. 10. Removing/Installing the Access Panels

## Requirements for the Hydraulic Connections



Make sure that the circuit is provided with a safety pressure relief valve and an expansion vessel that is appropriate for the appliance power and the system size, and the increase in temperature and pressure.



- ▶ The safety group must be installed no more than 1m from the appliance on the pipe with a diameter no less than that of the valve. No isolating valve may be installed between the appliance and the safety valve. The safety valve drainage must be connected into a pipe with a diameter no less than that of the valve itself.
- ▶ The pressure of the water network used to fill the appliance must be at least 0,8 bar.
- ▶ If the supply pressure from the network is higher than 6 bar, make sure to install a pressure reducing valve set at 4,5 bar.
- ▶ Verify the water quality of the network according to the requirements defined in this manual.
- ▶ In case inhibitors are used in the system, consult the manufacturer for product suitability.
- ▶ Any antifreeze used in the primary circuit must comply with Public Hygiene Regulations and must be non-toxic. A food-grade Propylene Glycol is recommended. It must be diluted according to the ratio recommended in the local regulations, but with a maximum ratio of 30%.



- ▶ Consult the appliance manufacturer to determine the compatibility of the antifreeze product with the appliance materials.
- ▶ It is recommended to install the following devices in the system to prevent water contamination :
  - ▶ Water filter and/or dirt separator installed on the return circuit. Have the water circulate for 2 hours after installation and prior to appliance start up in order to clean the circuit of contaminants. Clean the filter after filling the system.
  - ▶ Plate heat exchanger, combined with a micro-pollutant separator, which will protect the appliance from any contaminants present in an old heating system, where fittings and pipes can be corroded. This is also mandatory for open systems where oxygen can penetrate the system and cause corrosion.



- ▶ *The use of antifreeze in the primary circuit will lead to a reduction in the heating performance. The higher the concentration of antifreeze in the circuit, the lower the performance. Maximum output must be adjusted accordingly.*
- ▶ *The circuit diagrams are theoretical representations that do not necessarily include all the required safety devices. Make sure to correctly plan your system according to the applicable local regulations and standard practices.*

# PRODUCT INSTALLATION

## Water Quality Requirements to Prevent Scaling and Corrosion

To prevent the formation of scale and sludge in a closed heating circuit through the penetration of oxygen and carbonates, follow the recommendations below:

- ▶ Before filling the system, clean it according to standard EN14336. Chemical cleaning agents can be used.
- ▶ If the circuit is in bad condition, or the cleaning operation was not efficient, or there is a large volume of water in the system (e.g. cascade), it is recommended to separate the appliance from the heating circuit using a plate-to-plate heat exchanger or an equivalent accessory. In that case, it is recommended to install a hydro-cyclone or magnetic filter on the system side.
- ▶ Limit the fill operations. To control the quantity of water added into the system, install a water meter on the filling line of the primary circuit. No more than 5% of the total content of the system is allowed annually.
- ▶ Automatic filling systems are not recommended unless the fill frequency is checked and the levels of scale and corrosion inhibitor are maintained at an appropriate level.
- ▶ If the system needs to be refilled frequently, check for leaks in the primary circuit.
- ▶ Inhibitors may be used according to standard EN 14868.
- ▶ An air separator (on the appliance supply circuit) combined with a dirt separator (upstream of the appliance) must be installed according to the manufacturer's instructions.
- ▶ Additives can be used to keep the oxygen in solution in the water.
- ▶ Use the additives in accordance with the instructions of the manufacturer of the water treatment product.

### Water Hardness

- ▶ If the hardness of the fill water is higher than 20° fH (11,2° dH), soften it. At commissioning, the water should be soft.
- ▶ Check the water hardness regularly and enter the values in the maintenance log sheet (provided at the end of the manual).

Water hardness	°fH	°dH	mmolCa(HCO3)2 / l
Very soft	0 - 7	0 - 3,9	0 - 0,7
Soft	7 - 15	3,9 - 8,4	0,7 - 1,5
Fairly hard	15 - 25	8,4 - 14	1,5 - 2,5
Hard	25 - 42	14 - 23,5	2,5 - 4,2
Very hard	> 42	> 23,5	> 4,2

### Water Parameters

- ▶ In addition to the oxygen and the water hardness, other parameters of the water must be checked. Treat the water if the measured values are outside the range of the table below.
- ▶ In case the system operates at low temperature, it may be necessary to use an agent that inhibits the spread of bacteria.

Water Parameters	Range
Acidity	8,2 < pH < 9,0
Conductivity	< 400 µS/cm (at 25°C)
Chlorides	< 125 mg/l
Iron	< 0,5 mg/l
Copper	< 0,1 mg/l



Typical Hydraulic Connections - Heating Circuit

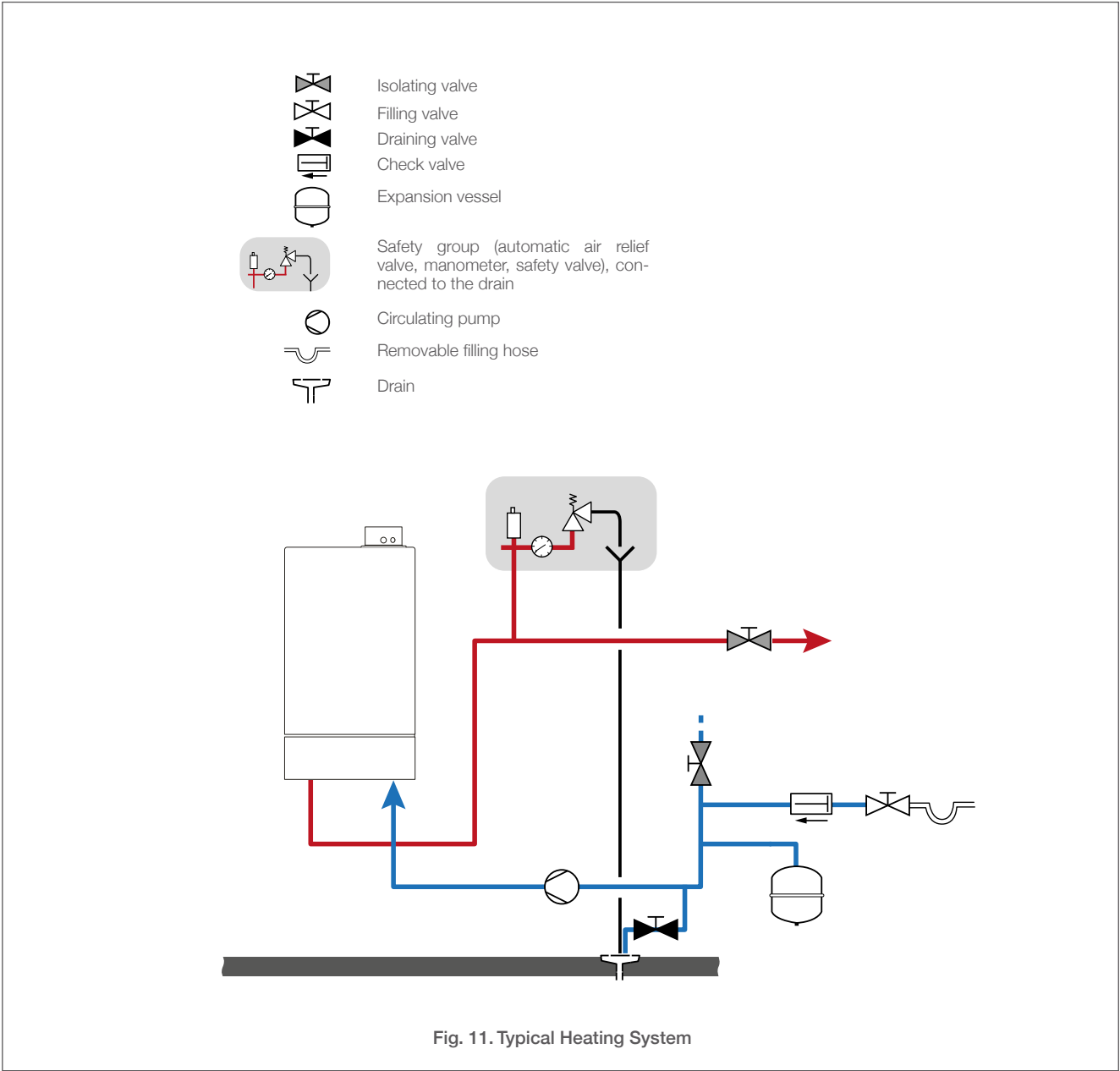
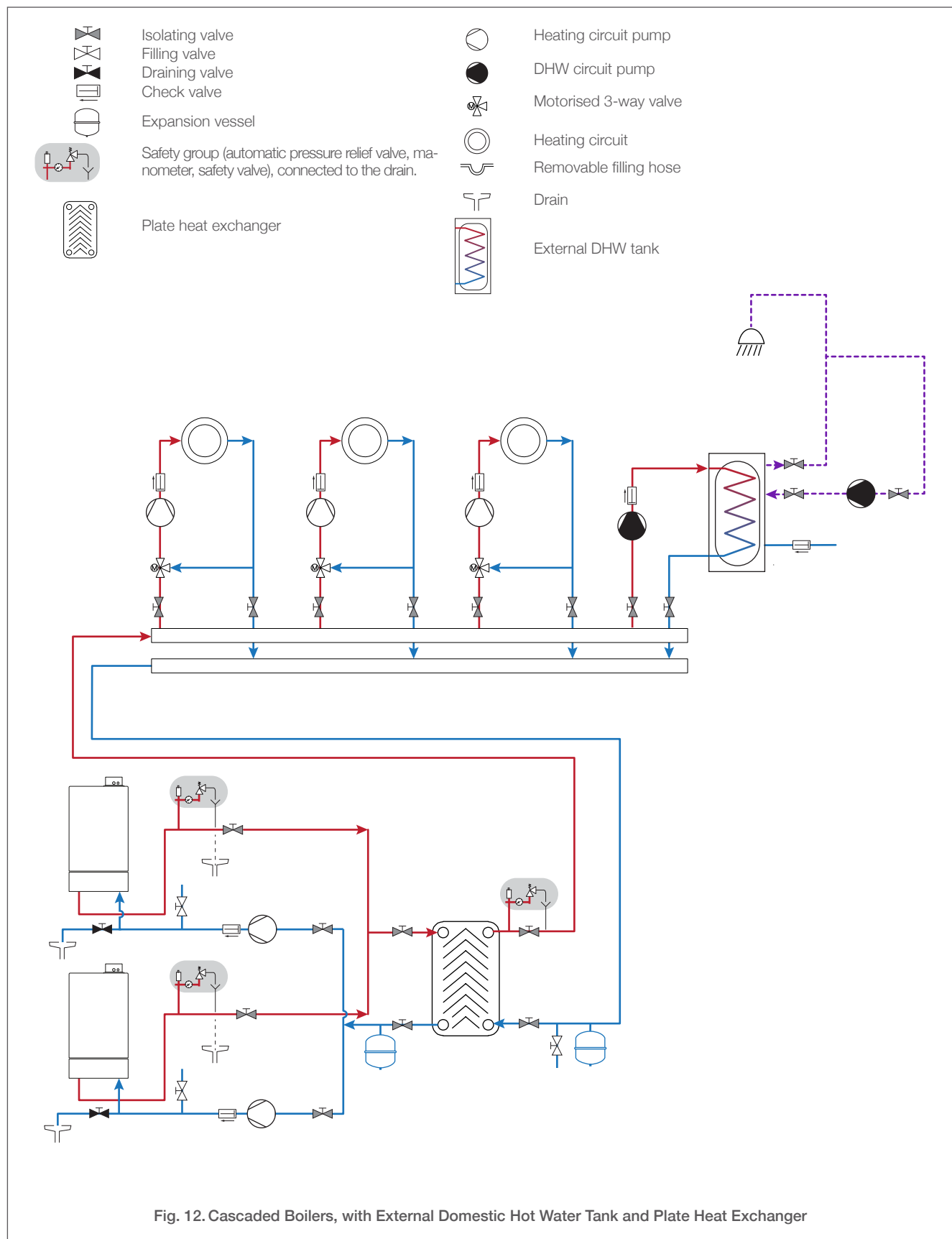

Fig. 11. Typical Heating System

# PRODUCT INSTALLATION

## Hydraulic Connections - Cascaded boilers, with External Domestic Hot Water Tank and Plate Heat Exchanger



Hydraulic Connections - Cascaded boilers, with External Domestic Hot Water Tank and Low Loss Header

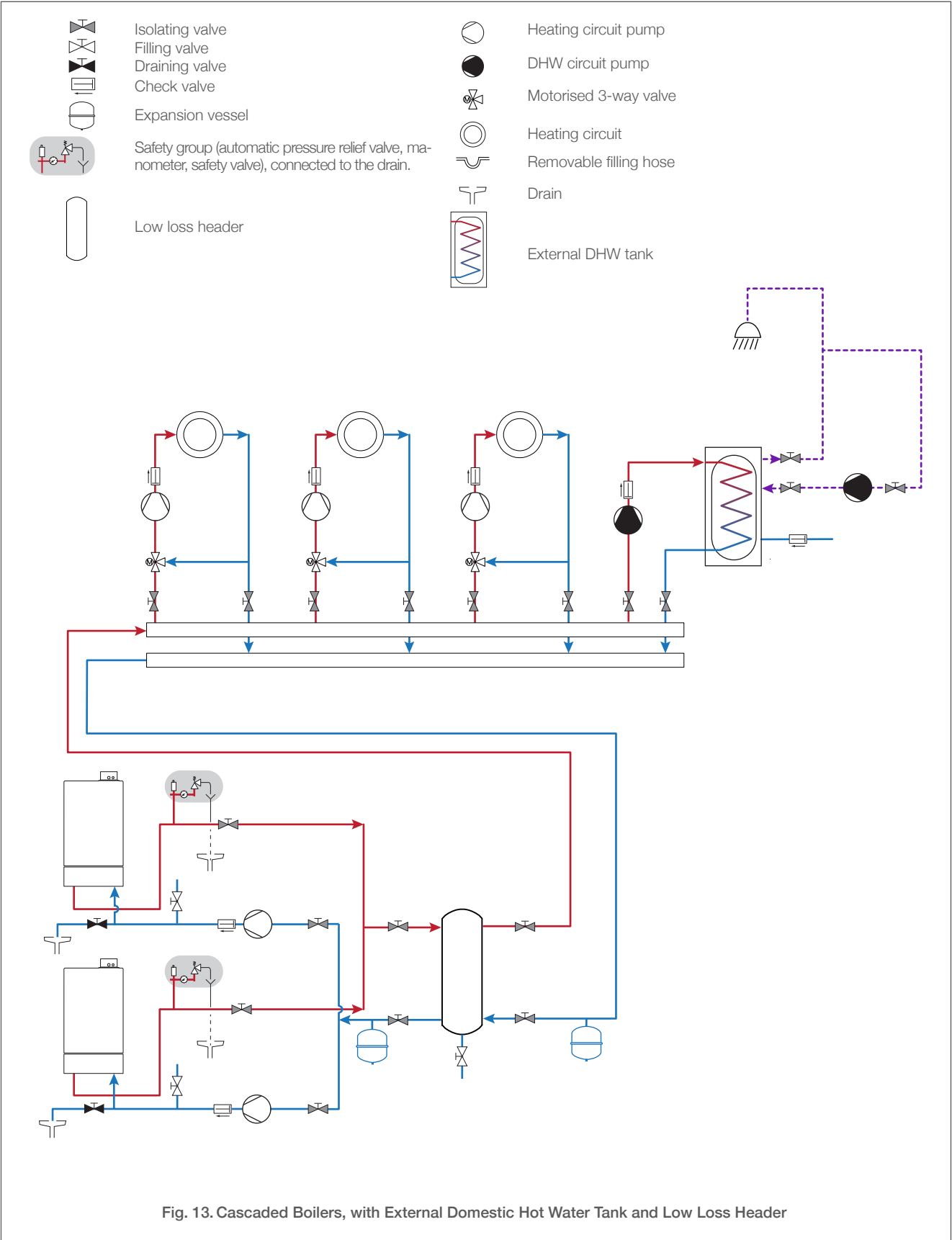

Safety Instructions for the Gas Connection



- ▶ When connecting the gas circuit, make sure to comply with all applicable local regulations and standards. The circuit will be equipped with a meter and a gas pressure regulator if required.
- ▶ Do not exceed the maximum gas pressure.
- ▶ The conversion of the appliance from natural gas to G31 liquefied petroleum gas (propane) or the reverse can only be performed by a qualified professional.
- ▶ Gas conversion shall be performed according to applicable local regulations. It is prohibited in some countries (e.g. Belgium). Perform conversion according to the gas category specified for your country on the appliance data plate.
- ▶ Bleed the gas duct and check thoroughly if all the internal and external gas pipes and connections are tight.
- ▶ After gas circuit connection, check that there is no leak.
- ▶ Use a gas detection device or perform a bubble test to check for gas leaks. Never use an open flame, as it could result in an explosion.



- ▶ Make sure that the gas type and pressure of the distribution network are compatible with the appliance, as per the information on the appliance data plate.
- ▶ The OFFSET (A) setting of the gas valve is factory-preset and sealed. In some countries, it is prohibited to change its setting. Please refer to applicable local regulations.
- ▶ The CO<sub>2</sub>, gas flow rate, air flow rate and air/gas supply parameters are factory-preset and may not be modified in certain countries. Please refer to applicable local regulations.



*Control the gas pressure and consumption at appliance start up, and perform the adjustment procedure provided in the commissioning section of this manual.*

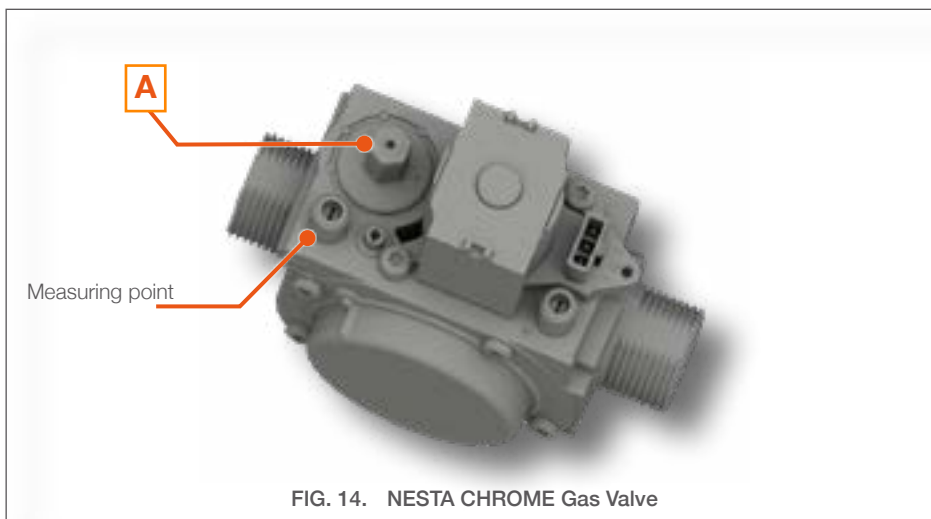

FIG. 14. NESTA CHROME Gas Valve

## Conversion to Propane

**Conditions:** OFF    

- Front panel removed. Please refer to **“Removing and Installing the Front Panel”** on page U-30 for the correct procedure.

### Tools and material:

- Conversion kit
- Wrench, hex head
- Torque wrench

### Procedure:

- Release the gas pipe elbow connection (3) from the gas valve (2).
- Remove two screws (1) from the gas valve bracket. Retain for reinstallation.
- Pull the gas valve slightly backwards to access the gasket (4).



**Do not exert too much force on the gas valve when moving it backwards to prevent damaging the attached gas pipe.**

- Check the condition of the gasket (4). Replace with a new one if it is damaged.
- Install the provided propane orifice (5) and reinstall with the (new) gasket (4), on the gas valve connection.



**Make sure to install, the orifice with its shouldered face towards the gas valve.**

- Tighten the gas pipe elbow connection (3) to the gas valve (2).
- Install gas valve bracket on burner plate using two retained screws (1). Torque at 4 Nm.
- Torque gas pipe elbow connection at 20 Nm.

### Follow-on Task(s)

- Adjust the fan speeds. Refer to **“Adjustment of Fan Speeds”** on page U-38.

Ø mm	Natural Gas (G20 - G25)	Propane (G31)
NC 24-32	None	4,35
NC 38-45	None	4,75

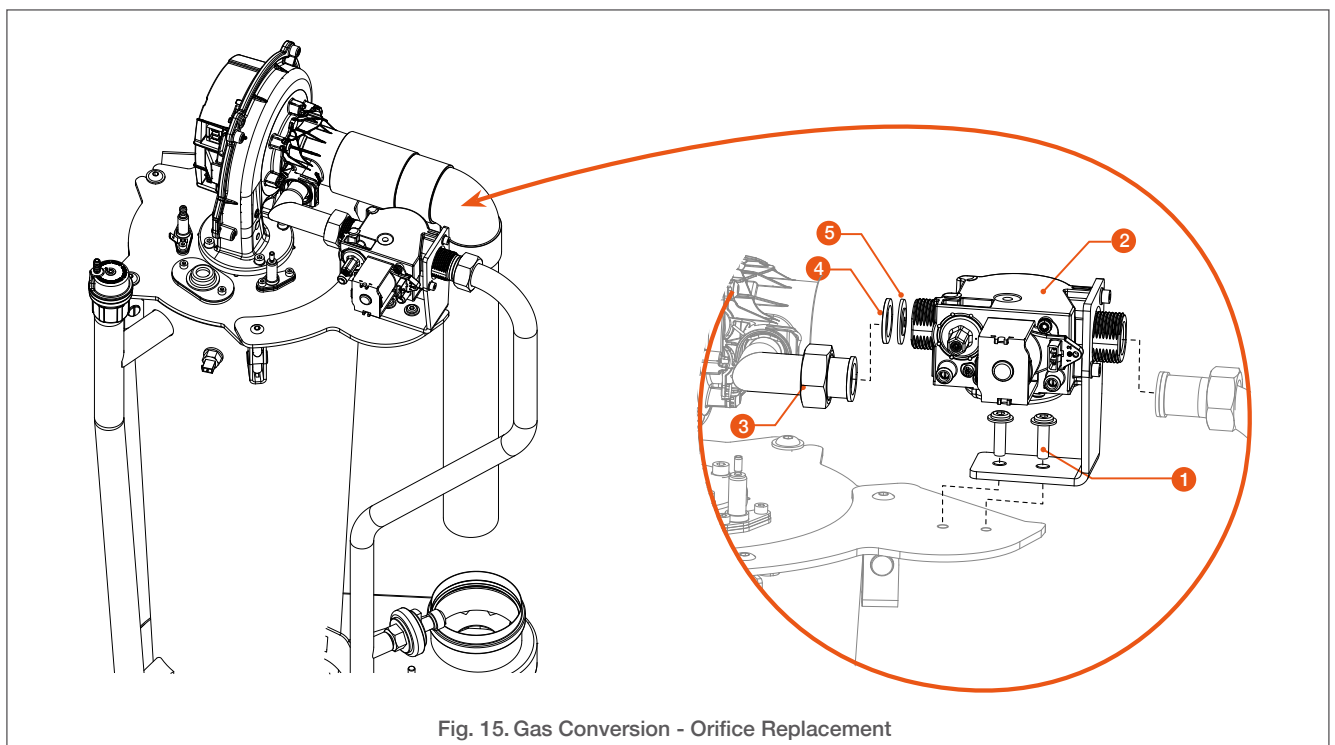



Fig. 15. Gas Conversion - Orifice Replacement

### Adjustment of Fan Speeds

**Conditions:**   

**Adjustment Procedure (Fig. 3):**

1. Start the boiler according to **“Start-up and Commissioning”** on page U-54.
2. Rotating the selector (1) and depressing it to confirm each selection:
  - ▶ select the  icon,
  - ▶ select **“Expert”**,
  - ▶ in **“Select user level”**; select **“Engineer”**, then **“Continue”**
  - ▶ select the  icon,
  - ▶ select **“complete parameter list”**,
  - ▶ select **“Time of day and date”** to access the list of menus.
3. Rotating the selector (1), scroll to the bottom of the list, **“Burner Control”**,
4. On page **“(4/12)”**, select **“9524 Required speed LF”**.
5. Press the selector (1) to modify the value. The value is displayed in white on a black background (2).

6. Rotating the selector (1), adjust the minimum fan speed according to the table shown at the bottom of the page.
7. Press the selector (1) to confirm and save the value.
8. Rotating the selector, go up the screen, back to the Burner Control page number. Select page number **“(4/12)”** by pressing the selector (1), then go to the following page.
9. On page **“(5/12)”**, select **“9529 Required speed HF”**. Press the selector (1) to modify the value. The value is displayed in white on a black background.
10. Rotating the selector (1), adjust the nominal fan speed according to the table shown at the bottom of the page.
11. Press the selector (1) to confirm and save the value.
12. Press the selector (1) for more than 3 sec. to exit the setting menu.

**Follow-on Task(s):**

- ▶ Perform the combustion adjustment. See **“Combustion Adjustment after Gas Conversion”** on page U-39.

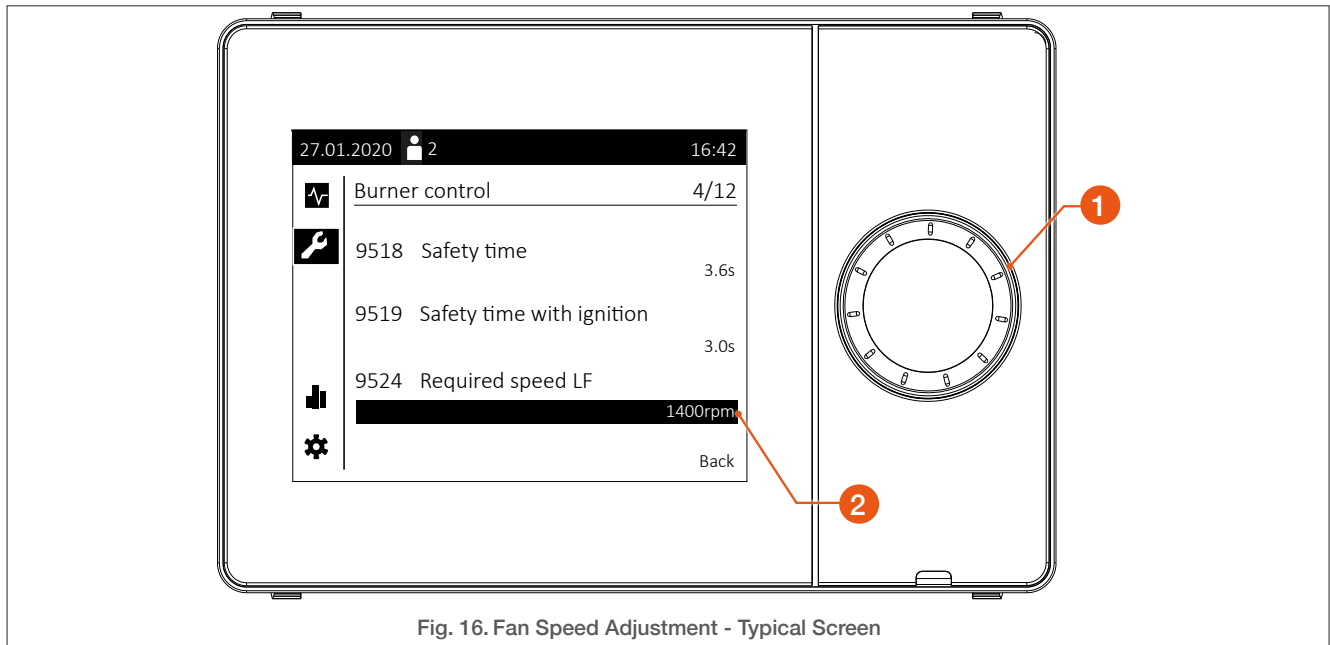





Fig. 16. Fan Speed Adjustment - Typical Screen

			N 24 WH	N 32 WH	N 38 WH	N 45 WH
Fan speeds for G20-G20Y20/G25 (Natural Gas)	Minimum	rpm	1350/1350	1350/1350	1430/1430	1430/1430
	Maximum	rpm	6600/6600	8850/9050	8300/9050	10360/10360
Fan speeds for G31 (Propane Gas)	Minimum	rpm	1350	1350	1430	1430
	Maximum	rpm	6300	8450	7600	9150

## Combustion Adjustment after Gas Conversion

**Conditions:**    

### Tools and material:

- ▶ Flue gas analyser
- ▶ Screwdriver, flat head, size 3
- ▶ Wrench, hex head, sizes 2 and 2.5

### Adjustment Procedure (Fig. 17 & Fig. 18):

1. Allow the boiler to operate for a few minutes.
2. Connect the flue gas analyser probe to the measuring port of the flue gas pipe.
3. Check CO<sub>2</sub> contents in the flue gas at max output as follows:
  - ▶ Using the rotary selector (1), select and activate the  icon,
  - ▶ Select “**Special operations (1/3)**”,
  - ▶ Set “**Chimney sweep function**” to “**On**”,
  - ▶ Set “**Burner output**” to “**Full load**”.
4. Check the CO<sub>2</sub> (or O<sub>2</sub>) contents displayed on the gas analyser, and compare the values with those in the table below.
5. If the value is outside the range, adjust the combustion value by turning the gas valve throttle (2, Fig. 18) in small steps. Allow the value to stabilise before performing additional adjustments.
  - Rotate throttle screw **clockwise (to the right) to decrease** the CO<sub>2</sub> contents.
  - Rotate throttle screw **counter-clockwise (to the left) to increase** the CO<sub>2</sub> contents.
6. Check CO<sub>2</sub> contents in the flue gas at min. output as follows:
  - ▶ Set “**Burner output**” to “**Partial load**”.
  - ▶ Check the CO<sub>2</sub> contents, and compare the values with those in the table at the bottom of the page.

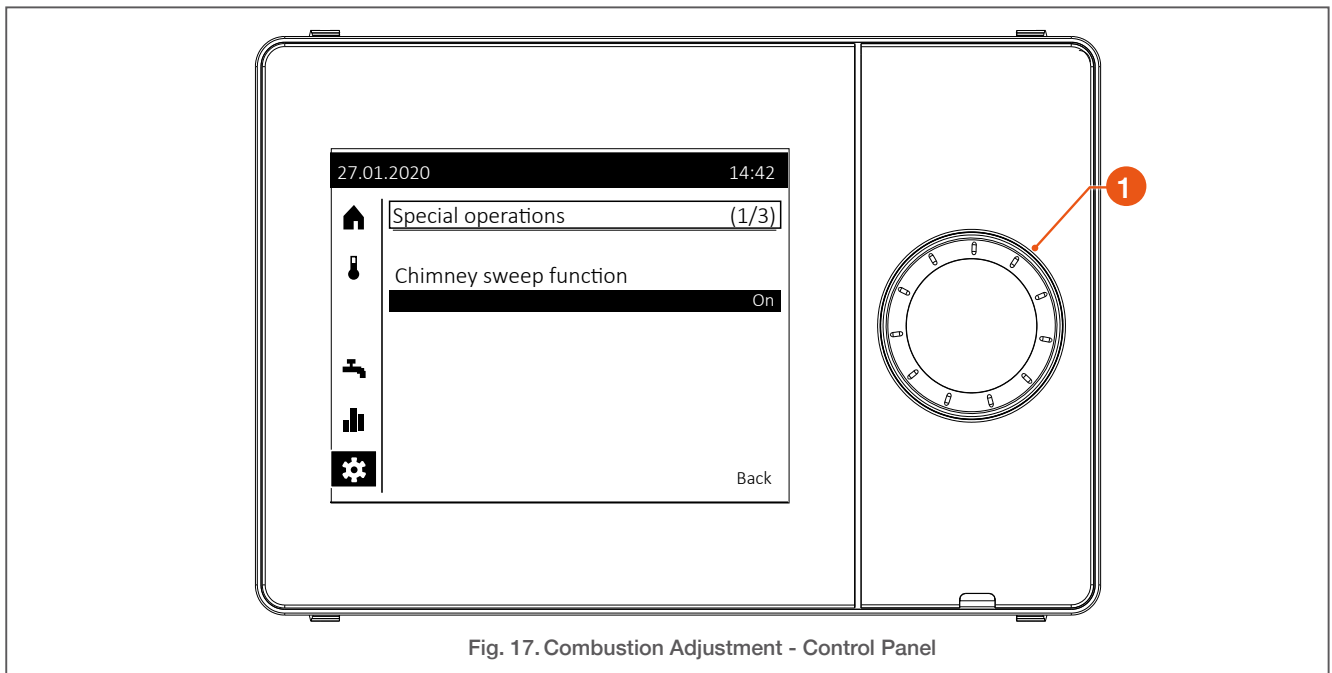

Fig. 17. Combustion Adjustment - Control Panel

		<b>N 24 WH</b> (min. - max.)*	<b>N 32 WH</b> (min. - max.)*	<b>N 38 WH</b> (min. - max.)*	<b>N 45 WH</b> (min. - max.)*
CO <sub>2</sub> contents (G20)	%	8,7-9,3±0,2	8,7-9,1±0,1	8,6-9,1±0,2	8,6-9,1±0,2
CO <sub>2</sub> contents (G25)	%	8,7-9,3±0,2	8,7-9,3±0,2	8,5-9,1±0,2	8,5-9,1±0,2
CO <sub>2</sub> contents (G31)	%	10,3-10,9±0,2	10,3-10,9±0,2	10,4-10,9±0,2	10,4-10,9±0,2
O <sub>2</sub> contents (G20/G20Y20)	%	5,4-4,3±0,3	5,4-4,6±0,15	5,5-4,6±0,3	5,5-4,6±0,3
O <sub>2</sub> contents (G25)	%	5,1-4,0±0,3	5,1-4,0±0,3	5,5-4,4±0,3	5,5-4,4±0,3
O <sub>2</sub> contents (G31)	%	5,2-4,3±0,25	5,2-4,3±0,25	5,0-4,3±0,3	5,0-4,3±0,3

\* (min. - max.) stands for “@Min output” and “@Max output”

## PRODUCT INSTALLATION

- ▶ If the value is outside the range, adjust the combustion value by turning the offset screw (3) in small steps. Allow the value to stabilise before performing additional adjustments.



*The offset screw (3) is factory-sealed. After adjustment, make sure to reseal it.*

7. In “**Special operations (1/3)**”, set “**Chimney sweep function**” to “**off**”.
8. Press the selector for more than 3 sec. to exit the setting menu.
9. Restart the boiler to check the ignition behaviour. Control the correct operation of the boiler by repeating steps 1 to 7.
10. Reseal the offset screw (3) using some paint or tape.

### **Follow-on Task(s):**

- ▶ On the gas valve (**Fig. 18**), place the yellow sticker indicating that a gas conversion has been carried out.
- ▶ On the data plate (back of the boiler), place the white sticker indicating that a gas conversion has been carried out.
- ▶ Reinstall front and top panels, Please refer to the appliance Installation and Maintenance manual for the correct procedure.
- ▶ Record the combustion values in the log sheet available in the installation manual of the appliance.

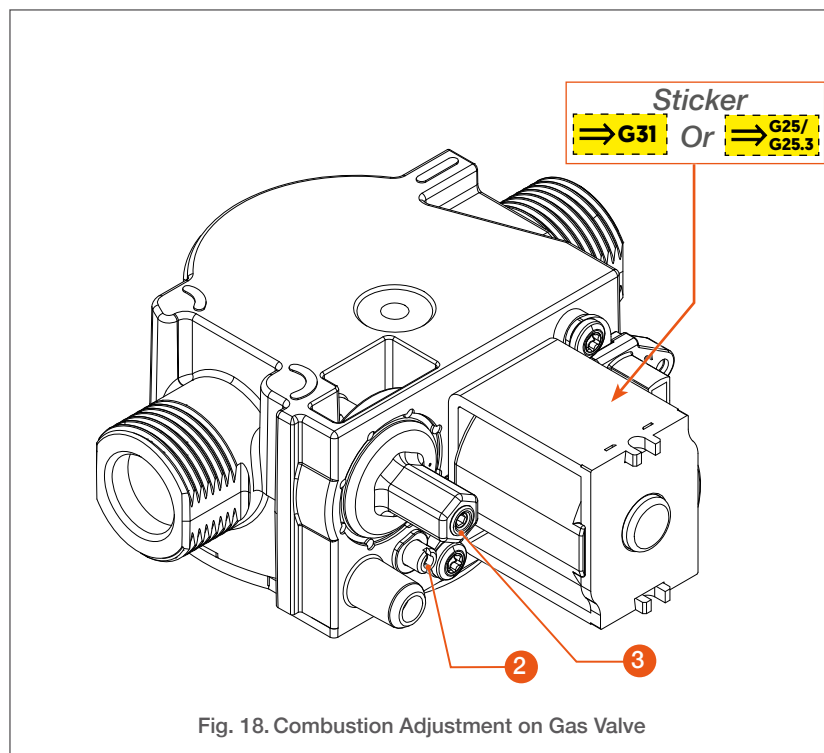

Fig. 18. Combustion Adjustment on Gas Valve



## Safety Instructions for the Chimney Connections



- › Verify installed combustion air and flue gas piping are tight and meet all provided instructions and applicable codes and standards.
- › Failure to properly support the flue system can cause failure, resulting in flue gases contaminating the ambient air.
- › The appliance must be equipped with flue system components from the same manufacturer and be approved by the appliance manufacturer. Ensure that the pipe and connection diameters all match to prevent any leaks from occurring.
- › Any gas-fired appliance generates carbon monoxide. Failure to install carbon monoxide detectors with alarm in the boiler room can result in serious injury, or death. Refer to applicable local regulations.
- › A condensate neutralisation system needs to be installed according to the applicable local regulations and standards. It must be cleaned and serviced regularly.



- › Do not install the appliance into a common flue pipe with appliances operating with a different type of gas or with oil. This will cause flue gas spillage or appliance malfunction. Please contact your AIC Technical Support for more information.
- › A condensation outlet connected to the sewer must be fitted close to the appliance.



- › Make sure to secure the flue piping to a solid structure.
- › Exclusively use the provided brackets to support the flue system.
- › When assembling the pipes, make sure not to put any stress on the components.
- › Install the horizontal flue pipes with a slight slope of 5 cm per meter (3°) back towards the appliance.
- › It is mandatory to ventilate the boiler room. The high or low air vent opening dimensions depend on the appliance power and the boiler room size. Refer to the local regulations in force.
- › If the combustion air inlet is located in an area likely to cause or contain contamination, or if products which could contaminate the air cannot be removed, the combustion air must be repiped and terminated at another location.
- › If the appliance is used on professional premises such as hairdresser's, cleaning company, painter's, etc. where chloride products, solvents, paints, dust etc. are likely to contaminate the air, make sure to install the appliance in a dedicated boiler room so that the appliance is supplied with clean combustion air.
- › In the case of parallel flue systems, make sure to maintain sufficient distance (at least 40 mm) between the appliance flue piping and combustible materials, and between the flue pipe and air inlet pipe if the latter is made of plastic material.

## PRODUCT INSTALLATION



➤ Flue pipe elements or PP air inlet elements should not be screwed together.

➤ Piping elements should not be bonded together using glue (e.g. silicone) or foam (e.g. PUR).



➤ Make sure to insulate the flue piping in damp rooms to avoid condensation water from forming and dripping.

- Cut the pipes squarely and deburr the edges. This will ensure correct sealing and prevent seals from being damaged.
- To ease the assembly of pipes, use exclusively a mixture of water and soap (1%) on the extremity of the pipe to be fit in.
- Metal flue pipes should always be fitted into the sleeve to the end stop.



➤ Plastic flue pipes should be allowed to expand under the effect of heat. Leave about 10 mm between the pipe and the sleeve end stop.

- The flue system should be fitted with an inspection opening.
- Do not exceed the maximum length recommended for the product when connecting the flue pipes, or the system power might decrease.
- For B- and C-type appliances, the flue gas exhaust pipes must at least comply with the category T120 H1 W1/2 O30 LI E U when using parallel piping and T120 H1 W1/2 O00 LI/LE E U0 when using concentric piping (EN 14471).
- The maximum length of duct must be calculated according to the permissible difference in pressure indicated in the technical specifications.

### General Instructions for the Installation of AIC-approved Chimney Components

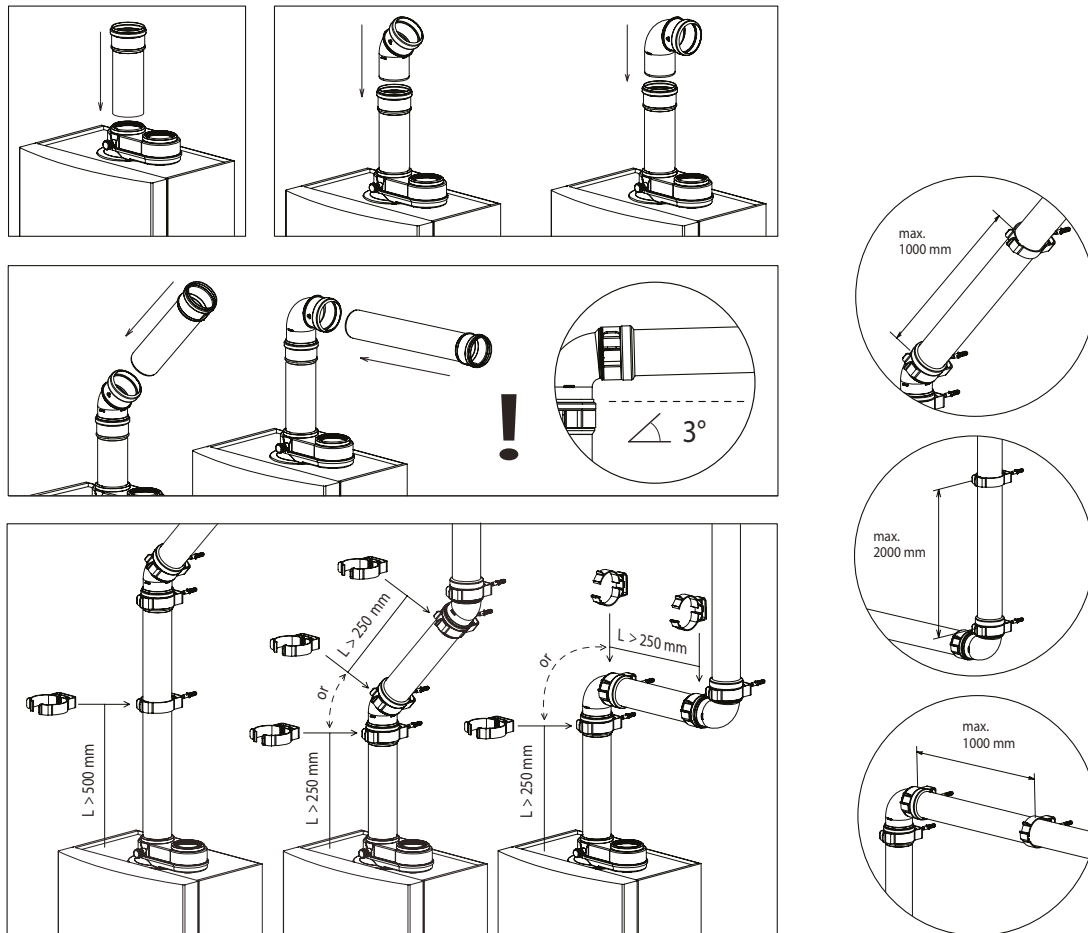

Chimney Connection

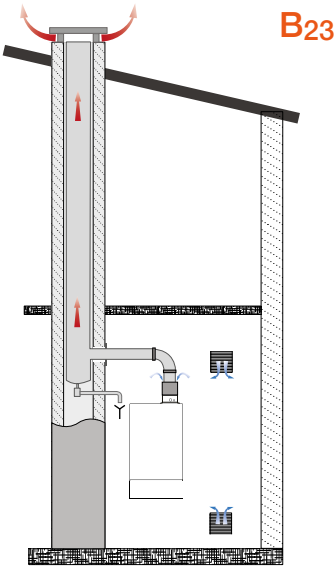

Combustion circuit	Open
Flue	Discharged to the outside
Combustion air	Drawn from the boiler room
Remark	Can be used for cascading



Make sure that the ventilation openings remain unobstructed at all times.

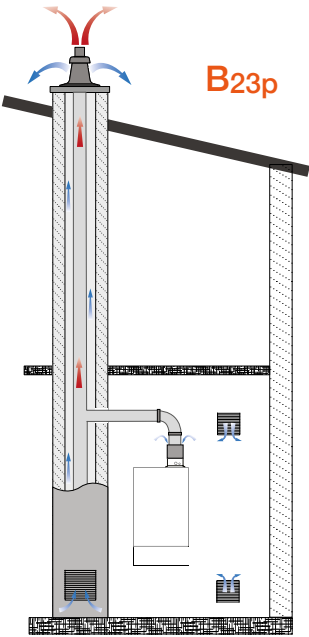

Combustion circuit	Open
Flue	Discharged to the outside, through positive pressure
Combustion air	Drawn from the boiler room
Remark	Can be used for cascading



Make sure that the ventilation openings remain unobstructed at all times.



Make sure to install AIC-approved components when building B23 and B23P systems. See “AIC-Approved Chimney Components” on page U-46.

# PRODUCT INSTALLATION

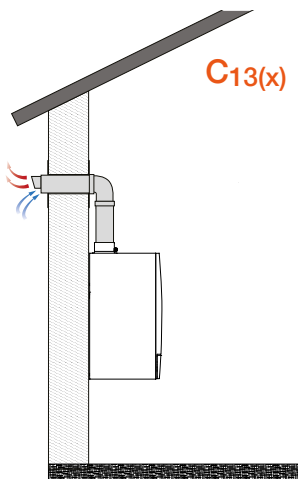

Combustion circuit	Sealed
Connection	Horizontal (wall) terminal
Air inlet/flue outlet orifices	Concentric - to a terminal for admission of combustion air from the outside AND flue discharge to the outside

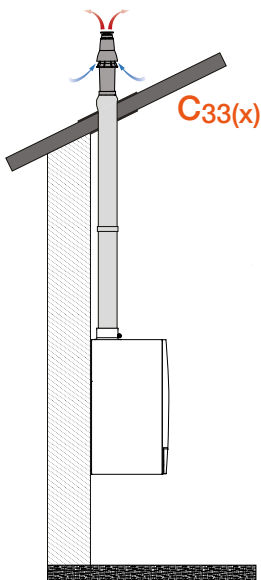

Combustion circuit	Sealed
Connection	Vertical terminal
Air inlet/flue outlet orifices	Concentric - to a terminal for admission of combustion air from the outside AND flue discharge to the outside

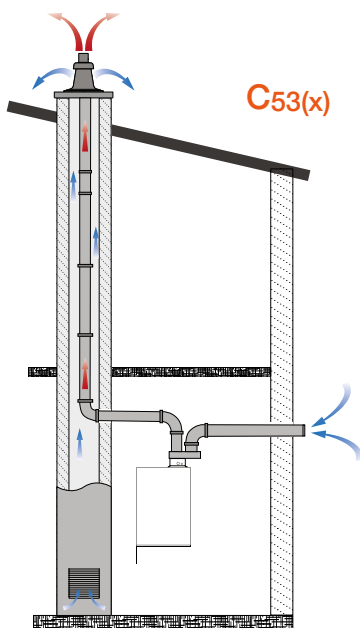

Combustion circuit	Sealed
Connection	Via separate ducts
Air inlet/flue outlet orifices	Through separate terminals that may terminate in zones of different pressures
Additional requirement	Orifices may NOT terminate on opposite walls of the building

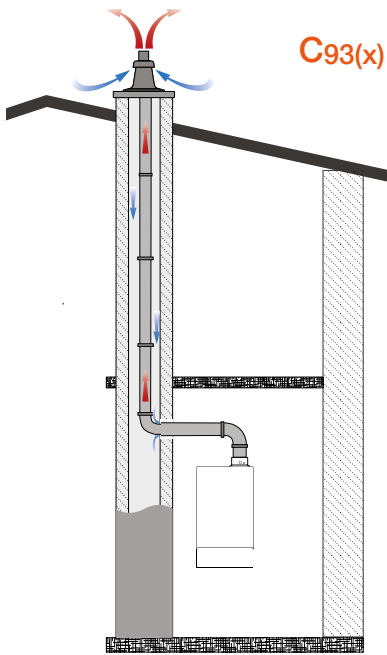

Combustion circuit	Sealed
Connection	Vertical terminal
Air inlet/flue outlet orifices	<p>Separate ducts, both connected to a roof terminal:</p> <ul style="list-style-type: none"> <li>‣ Flue duct: connected to a vertical terminal</li> <li>‣ Air inlet: through an existing duct</li> <li>‣ Roof terminal admits combustion air from the outside AND discharges flue to the outside</li> </ul> <p>OR</p> <ul style="list-style-type: none"> <li>‣ Both orifices are close enough to come under similar wind conditions.</li> </ul>
Remark	<p>Airtight operation is possible in existing chimney, provided that:</p> <ul style="list-style-type: none"> <li>‣ It has been cleaned prior to installation</li> <li>‣ Clearance area is sufficient for combustion air (min the size of 2 separate ducts)</li> </ul>



**Make sure to install AIC-approved components when building C13(x), C33(x), C53(x) and C93(x) systems. See “AIC-Approved Chimney Components” on page U-46**

### C63

Combustion circuit	Sealed
Connection	To a system that is approved and sold separately (external supplier)
Air inlet/flue outlet orifices	<p>May terminate in zones of different pressure</p> <ul style="list-style-type: none"> <li>‣ Maximum allowable draught is 200 Pa.</li> <li>‣ Maximum allowable pressure difference between combustion air inlet and flue gas outlet (including wind pressures) is indicated in the technical specifications.</li> <li>‣ maximum allowable temperature of combustion air is 40°C.</li> <li>‣ Condensate flow is allowed into the appliance.</li> <li>‣ Maximum allowable recirculation rate of 10% under wind conditions</li> <li>‣ Orifices may NOT terminate on opposite walls of the building</li> <li>‣ The flue gas exhaust pipes must at least comply with the category T120 H1 W1/2 O30 LI E U when using parallel piping and T120 H1 W1/2 O00 LI/LE E U0 when using concentric piping (EN 14471).</li> </ul>
Additional requirement	



**This type of connection is prohibited in some countries - refer to local regulations and standards in force**



*Please also refer to the additional information in “Engineering the Chimney System” on page U-48 for the construction of your chimney system.*

AIC-Approved Chimney Components

	Art. Designation	AIC Art. code	
Concentric System 80/125 mm	ROOF TERM SKYLINE STD PP 80/125 AR300	1424200025	
	ROOF TERM SKYLINE STD PP 80/125 AR580	1424200026	
	WEATHER SLATE STEEP LEAD 80/125 25°-45°	1424500014	
	WEATHER SLATE FLAT AL 80/125	1424500015	
	WALL TERM MUGRO STD 80/125 incl. Wall Plates	1424200027	
	EXTENSION PP 80/125X 250 EPDM	1424200028	
	EXTENSION PP 80/125X 500 EPDM	1424200029	
	EXTENSION PP 80/125X1000 EPDM	1424200030	
	EXTENSION PP 80/125X2000 EPDM	1424200031	
	EXTENSION ADJUSTER PP 80/125 EPDM	1424200032	
	ELBOW PP 80/125 90° SHORT EPDM	1424200033	
	ELBOW PP 80/125 45° SHORT EPDM	1424200034	
	INSPECTION ELBOW PP 80/125 90° SHORT EPDM	1424200035	
	TEE PP 80/125 + COVER EPDM	1424200036	
	EXPANDER PP 80/125-100/150 EPDM	1424200037	
	CHIMNEY CONNECTION 80/125	1424200038	
	WALL BRACKET 125	1424200039	
	Twin pipe System 80	ADAPTER PP 80-125 HOH120 + PP PIPE	1424300010
		ROOF TERMINAL SKYLINE PP 80/80 AR 300 7021	1424300016
		ROOF TERMINAL SKYLINE PP 80/80 AR 580 7021	1424300056
WEATHER SLATE STEEP LEAD 80/125 25°-45°		1424500014	
WEATHER SLATE FLAT AL 80/125 0°		1424500014	
WALL TERMINAL MUGRO 80/80		1424300057	
EXTENSION PP 80 X 250 EPDM		1424300019	
EXTENSION PP 80 X 500 EPDM		1424300020	
EXTENSION PP 80 X 1000 EPDM		1424300021	
EXTENSION PP 80 X 2000 EPDM		1424300022	
EXTENSION ADJUSTER PP 80 EPDM		1424300023	
ELBOW PP 80 90° EPDM		1424300024	
ELBOW PP 80 45° EPDM		1424300025	
SUPPORT ELBOW PP 80 90° EPDM		1424300026	
TEE PP 80 90° + COVER EPDM		1424300027	
EXPANDER PP 80-100 EPDM		1424300028	
CHIMNEY TOP PP 80 incl. ventilation incl. INOX pipe		1424300029	
SUPPORT CHIMNEY		1424500008	
CHIMNEY SHAFT COVER 80		1424300030	
SHAFT DISTANCE HOLDER PP 80 (2 pcs)		1424300031	
WALL BRACKET 80 PP		1424300032	
CHIMNEY AIR PLATE AL. 250 x 300		1424300033	
AIRCOVER FOR TERMINAL 80-125		1424300034	
AIR INLET GRILL 125-80		1424300035	

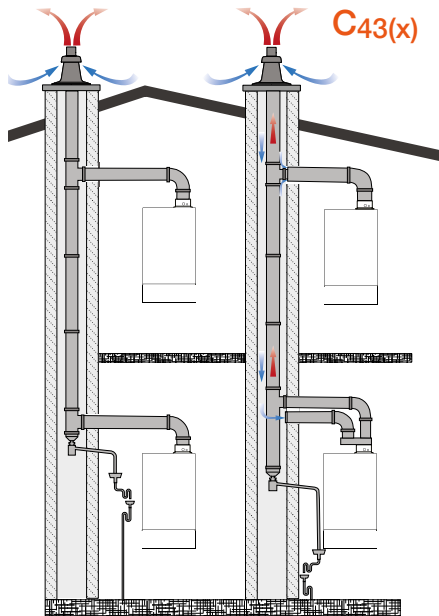

Combustion circuit	Sealed
Connection	Via two ducts to a common duct system (part of the building, designed for more than one appliance)
Air inlet/flue outlet orifices	through a roof terminal that admits combustion air from the outside AND discharges flue to the outside > Concentric ducts OR > Both orifices are close enough to come under similar wind conditions
Additional requirements	> Chimney with natural draught only > Condensate flow is not allowed into the appliance

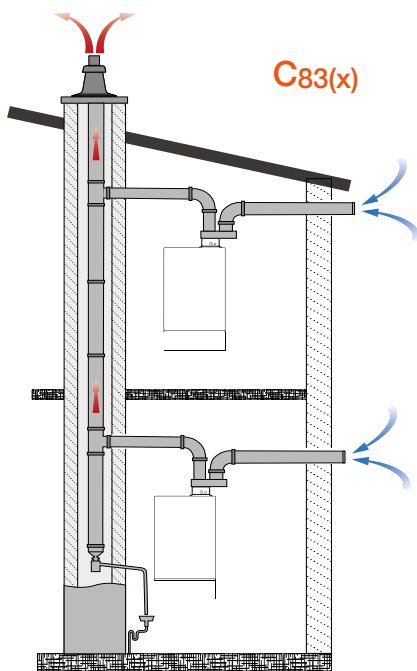

Combustion circuit	Sealed
Connection	Through: > a single duct system OR > a common duct system (part of the building, designed for more than one appliance)
Air inlet/flue outlet orifices	> Flue is discharged to the roof > Combustion air is taken from the outside
Additional requirement	> Condensate flow is not allowed into the appliance



- > When connecting several boilers to the same duct (i.e. types C43x, C83x or cascades), make sure to install an AIC-approved flue gas damper on each boiler in the system.
- > For B23p chimney cascade, please contact your AIC representative.



Please also refer to the additional information in “Engineering the Chimney System” on page U-48 for the construction of your chimney system.

### Engineering the Chimney System



The chimney system must be engineered by a qualified professional, according to local standards and regulations. The overall installation resistance of each boiler should not exceed the value indicated in the combustion table (including maximum wind condition) measured at the outlet of each boiler at maximum output. Refer to “Combustion Data” on page G-15.

Please contact your AIC representative for more information



› The flue system length must be calculated so as to ensure a safe performance of the system. See “Calculation of the chimney length” on the right.

- › Make sure to install the boiler with the shortest length of combustion air and flue ducts.
- › When several boilers need to be connected to a common duct, please contact your AIC representative for more information.
- › For C43(x), C63(x) and C83(x) chimney type connections, please consider the following dimensions of the concentric connection for the definition of the components in your chimney system.

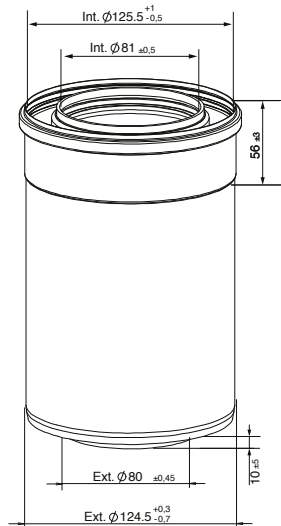

### Accessories





If required by local regulations, install a condensate neutralisation system. In that case, it may be necessary to install the boiler on a base to get sufficient downward flow. If flow is not sufficient, install a condensate pump.

### Calculation of the Chimney Length

The chimney length must be calculated using the values in the tables below for both parallel and concentric configurations.

1. Compose your system.
2. Add up the values from the tables below (straight pipes and elbows), of all the components used in the chimney system.
3. Compare the resulting value with the maximum length value for your type of chimney connection (parallel or concentric.)

#### Equivalent Length of Chimney Components

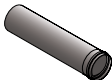
	90°	45°	1 m
Parallel connection (N 24 to N 45 WH)			
	2,16	0,91	1
Concentric connection (N 24 to N 45 WH)			
	1,43	0,81	1

#### Maximum Chimney Length (terminals incl.)

	Parallel	Concentric 80/125
N 24 - 32 WH	16 m	15 m
N 38 - 45 WH	15 m	15 m



The resulting value must be lower than the maximum value indicated in the table above for the considered appliance. Failure to comply can result in severe injuries or death.



## Safety Instructions for the Electrical Connections



Electrical connections must be carried out by a qualified professional in accordance with current standards and regulations in force.



- ▶ When the appliance is connected to the electrical network, it must be earthed.
- ▶ Make sure that a fuse or circuit breaker of the recommended rating (B10A or according to applicable local regulations) is installed outside the appliance, to allow electrical isolation.
- ▶ Do not touch the appliance with any wet body parts when it is supplied with electrical power.
- ▶ Before performing any operation on the electrical circuit, isolate the electrical supply of the appliance through the external power-cutting device (fuse, circuit-breaker, etc.)
- ▶ When routing the cables through sharp-edged holes in the panels, make sure to install glands or grommets, and to secure the cables in order to prevent any damage.



- ▶ Make sure to make the connections to the correct terminals, as indicated on the wiring diagram. If high voltage cables are installed on a low-voltage terminal, the electronic board will be damaged.
- ▶ When connecting wires to the terminals, check that the connection is secure and that all the wire strands are tightly held

## Cables



Any damaged power supply cable must be replaced using cables as described below and installed by a qualified professional.

The cross-section of the wires should be at least 1,5 mm<sup>2</sup> and maximum 2,5 mm<sup>2</sup>, and equipped with sleeves at L, N and ground (⊥) wire ends.

High voltage wiring is connected to a terminal strip located at the front of the boiler.

The main board and the low-voltage terminal strip are also located at the front of the boiler

## Routing the Cables

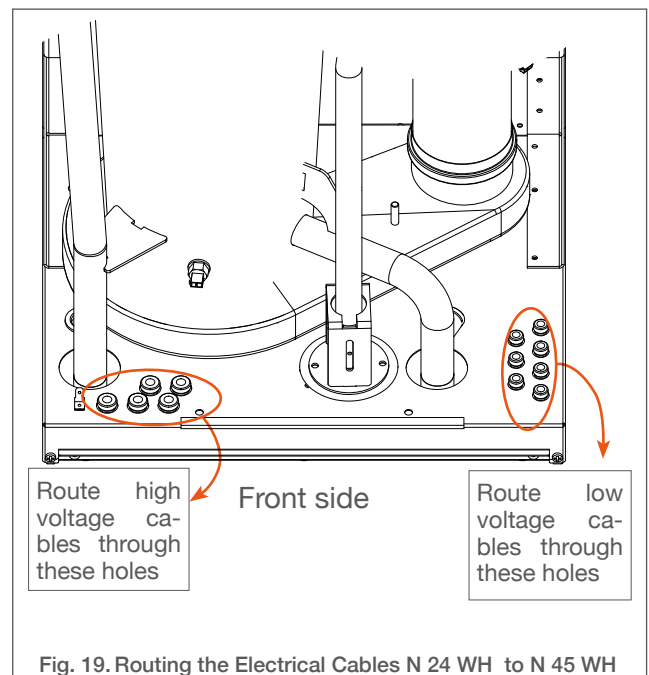
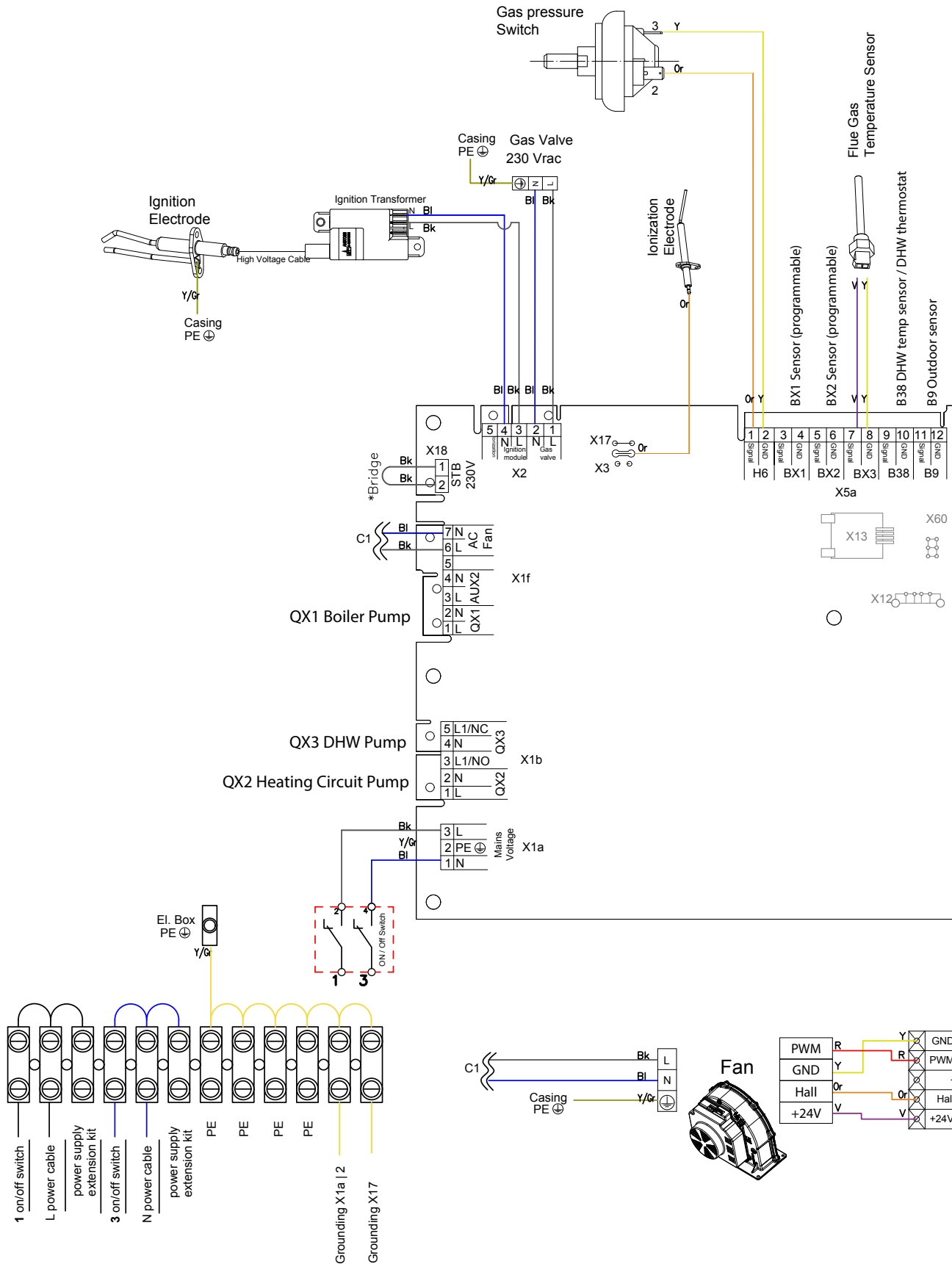



Fig. 19. Routing the Electrical Cables N 24 WH to N 45 WH

# PRODUCT INSTALLATION

## Wiring Diagram



 *If no room thermostat is installed on H5, install a bridge on 7 & 8 terminals*

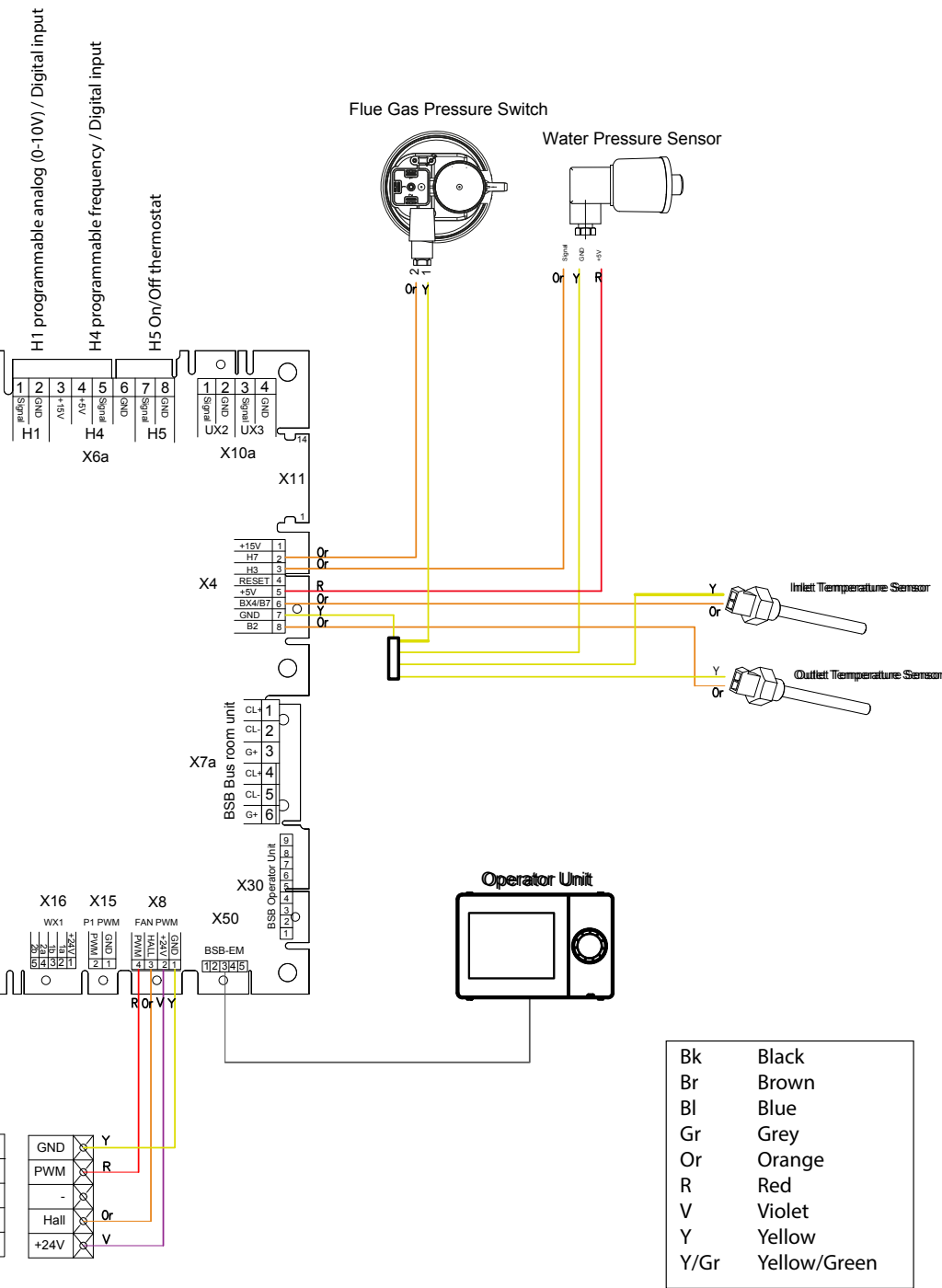

Bk	Black
Br	Brown
Bl	Blue
Gr	Grey
Or	Orange
R	Red
V	Violet
Y	Yellow
Y/Gr	Yellow/Green

Accessing the High and Low Voltage Terminal Strips and Electronic Board



**Make sure that the power supply to the appliance is deactivated (power supply cable disconnected from the boiler) before accessing the high voltage terminal strip.**

**Conditions:** OFF  

**Tools and material:**

- Wrench, hex head, size 3

**Procedure:**

- Remove boiler front panel, see *“Removing and Installing the Front Panel”* on page U-30.

- Remove one screw. Retain for installation.
- Lower the main electronic casing (along with optional extension module casing if it is installed).
- Release four screws and remove protective cover. Retain hardware for reinstallation.
- Repeat the process for the optional extension module casing if it is installed.
- Proceed in the reverse order to reinstall the protective covers and set the casings back in position.

**Follow-on tasks:**

None

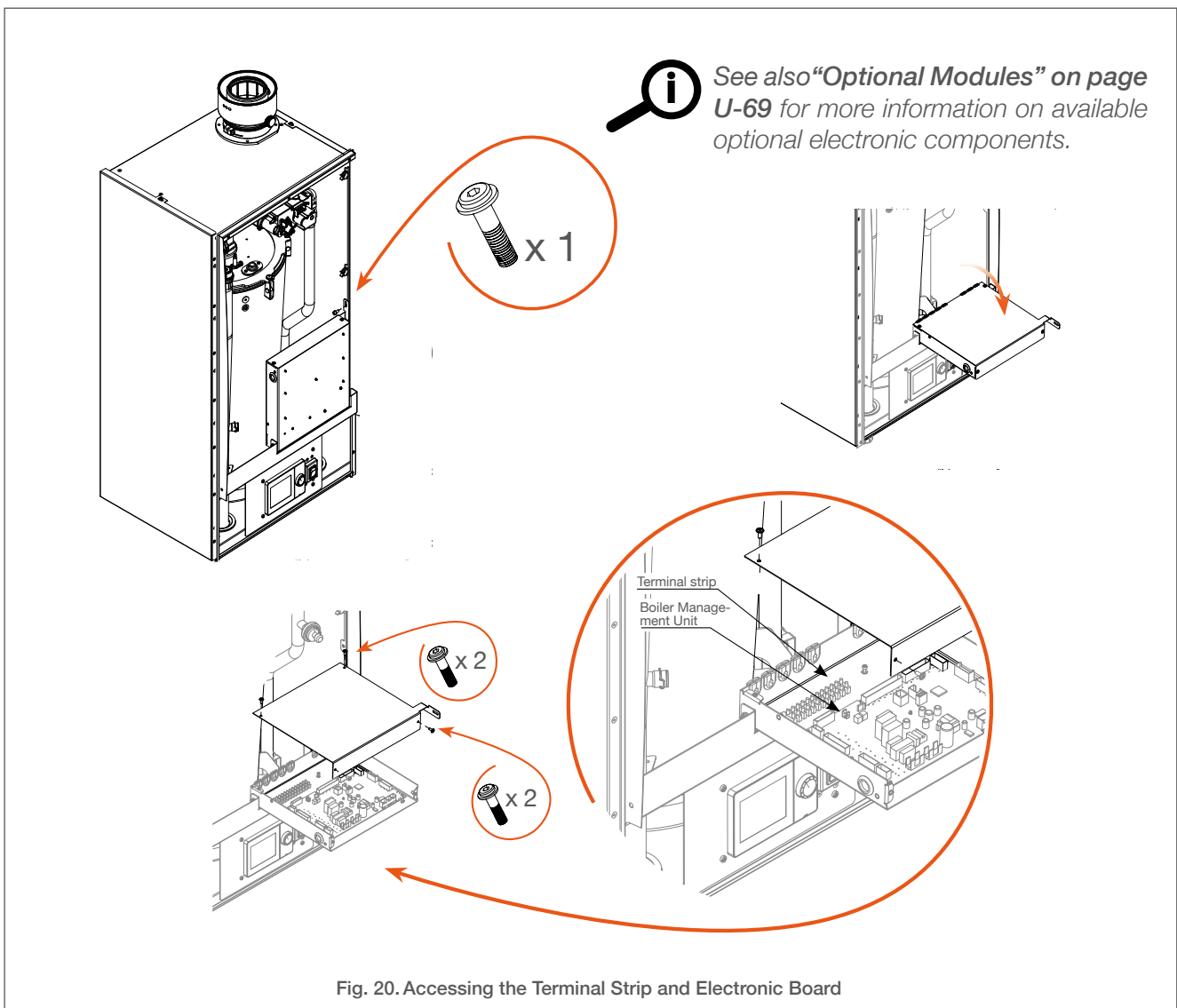

Fig. 20. Accessing the Terminal Strip and Electronic Board

## Safety Instructions Before Start-up



- › Check that all connections (electrical, flue pipe, hydraulic, gas) have been carried out and that they are tight and secure.
- › Ensure that the condensate trap is full of water before starting up the appliance.



- › Before starting the appliance, check that the heating circuit is full of water and the appliance is supplied with gas and electrical power.
- › Check that the gas pressure is within the allowed range.
- › Check that the water pressure is sufficient (at least 0,8 bar when cold). Low water pressure is detected by the appliance sensor and will be indicated on the control panel display. Top up the circuit as required.
- › In case of repeated indication of low pressure in the water circuit, check for leaks and repair as required.
- › Once the filling of the heating circuit is complete, close the filling valve.



Once the initial start-up process is complete, fill in the installation checklist with all the relevant information on the system for future reference. Refer to “Installation Checklist” on page U-86.

## Filling the System

**Conditions:**



**Procedure:**

1. Connect the filling hose (≡) to the system filling valve (⊗) and to the water network tap.
2. Make sure that the draining valve (⊗) is closed.
3. Open the isolating valves (⊗).
4. Open the filling valve (⊗) and the water network tap.
5. Bleed the air from the system and bring the system pressure at minimum 1,2 bar.



Pressure should be suitable for the size/height of the heating system and take into account the pressure rating of the safety valve.

6. Close the filling valve (⊗).
7. Remove the filling hose (≡) from the filling valve (⊗) as required.

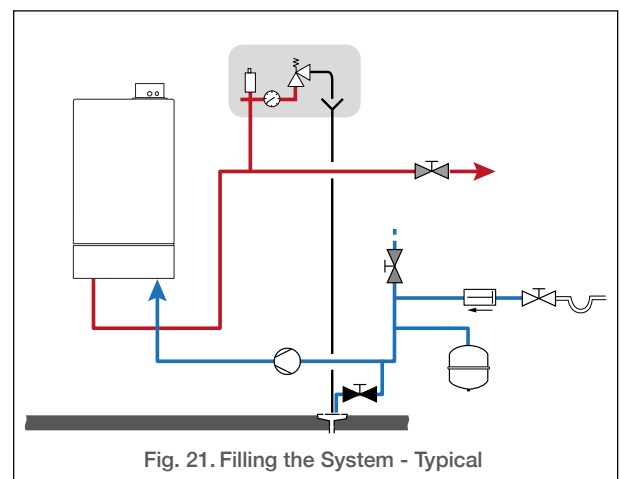

**Follow-on Task(s):** None

## COMMISSIONING

### Start-up and Commissioning

#### Conditions:



- ▶ Check the gas type before performing the procedure

#### Tools and material:

None

#### Procedure:

1. Press the On/Off switch located on the right side of the control panel.



*When starting the boiler for the first time after installation, the controller will open the Commissioning Wizard automatically. This wizard process only appears once, provided that the function is disabled (set to “off”) at completion of the process. To bypass it, activate “Continue” or “Skip” displayed at the bottom of the screen, until you reach the end of the process.*

2. If required, perform the commissioning setting of the boiler, following the instructions displayed on the screen. Refer to **“Commissioning Wizard” on page U-56** for more information and a list of the settings.

#### Follow-on task(s):

Perform the combustion adjustments, as described in the following section.

## Combustion Adjustments (G20/G25/G31)

**Conditions:**    

### Tools and material:

- ▶ Flue gas analyser
- ▶ Screwdriver, flat head, size 3
- ▶ Wrench, hex head, sizes 2 and 2.5

### Procedure:

1. Allow the boiler to operate for a few minutes.
2. Connect the flue gas analyser probe to the measuring port of the flue gas pipe.
3. Check CO<sub>2</sub> contents in the flue gas at max output as follows:
  - ▶ Select and activate the  icon
  - ▶ Select “**Special operations (1/3)**”
  - ▶ Set “**Chimney sweep function**” to “**on**”.

 *The chimney sweep function will remain “on” for one hour, unless it is set to “off”.*

- ▶ Set “**Burner output**” to “**Full load**”.
- ▶ Check the CO<sub>2</sub> (or O<sub>2</sub>) contents displayed on the gas analyser, and compare the values with those in the technical specifications (See “**Combustion Data**” on page G-15).
- ▶ If the value is outside the range, adjust combustion by turning the gas valve throttle screw **(1)** in small steps:
  - Rotate throttle screw clockwise (to the right) to decrease the CO<sub>2</sub> rate.
  - Rotate throttle screw counter-clockwise (to the left) to increase the CO<sub>2</sub> rate.
- ▶ Allow the value to stabilise before checking the value again and performing additional adjustments.

### Follow-on task(s):

Record the value in the log sheet. Refer to “**Combustion Parameters - Log Sheet**” on page U-89.

## Combustion Adjustments (G20Y20)

**Conditions:**    

### Tools and material:

- ▶ Flue gas analyser
- ▶ Screwdriver, flat head, size 3
- ▶ Wrench, hex head, sizes 2 and 2,5

### Procedure:

1. Allow the boiler to operate for a few minutes.
2. Connect the flue gas analyser probe to the measuring port of the flue gas pipe.
3. Check O<sub>2</sub> contents in the flue gas at max output as follows:
  - ▶ Select and activate the  icon
  - ▶ Select “**Special operations (1/3)**”
  - ▶ Set “**Chimney sweep function**” to “**on**”.
  - ▶ Set “**Burner output**” to “**Full load**”.
  - ▶ Check the O<sub>2</sub> contents, and compare the values with those in the technical specifications (See “**Combustion Data**” on page G-15).
  - ▶ If the value is outside the range, adjust the combustion value by turning the gas valve throttle **(1)** in small steps, to allow the value to stabilise before performing additional adjustments.
    - Rotate throttle screw clockwise (to the right) to increase the O<sub>2</sub> rate.
    - Rotate throttle screw counter-clockwise (to the left) to decrease the O<sub>2</sub> rate.
4. In “**Special operations (1/3)**”, set “**Chimney sweep function**” to “**off**”.

### Follow-on task(s):

Record the value in the log sheet. Refer to “**Combustion Parameters - Log Sheet**” on page U-89.

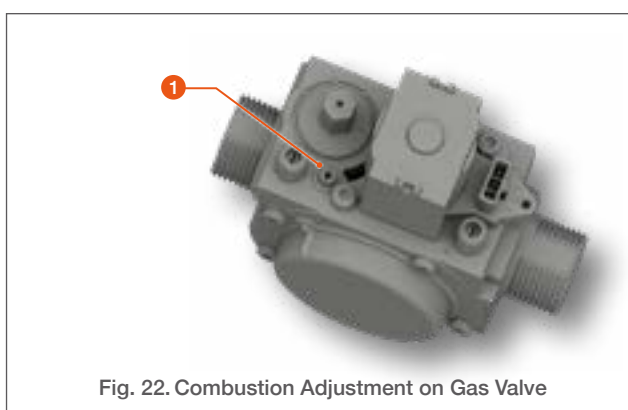

Fig. 22. Combustion Adjustment on Gas Valve

# COMMISSIONING

## Commissioning Wizard

When starting up the boiler for the first time, a commissioning wizard will be displayed, unless it has been disabled before (e.g. from factory or through a previous manual deactivation). In that case, and if needed, it can be accessed through the “Commissioning” or “Engineer” user level.



The following pages give a view of the structure of the commissioning wizard contents. Program numbers are provided as well as the detail of the menu when required. In orange is the default or recommended value. Please also refer to “Structure of Menus for the Installer” on page U-75.



To exit the commissioning wizard without adjustments, activate “Continue” or “Skip” displayed at the bottom of the screen, until you reach the end of the process.

Symbols used for the **operation of the selector**:



turn the selector to the left or to the right.



depress shortly the rotary selector.



turn the selector to adjust the value, then depress the selector to validate.

## Accessing the Commissioning Wizard

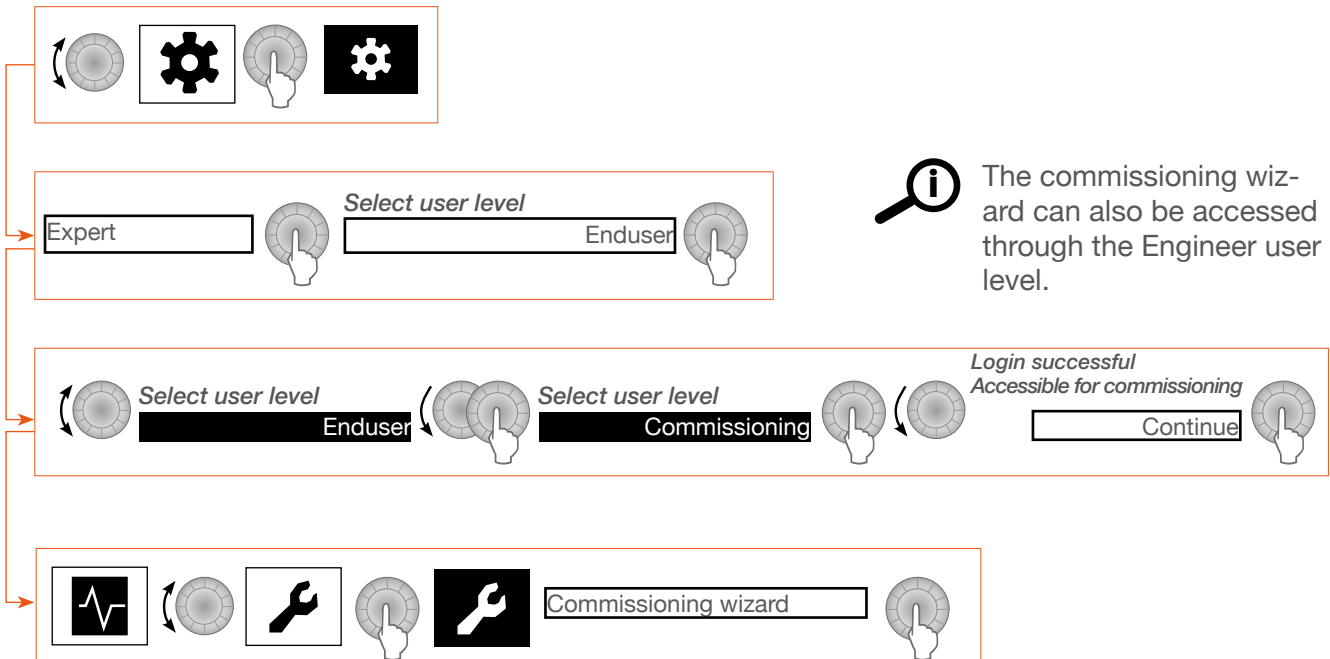

The commissioning wizard can also be accessed through the Engineer user level.



General Structure of the Commissioning Wizard

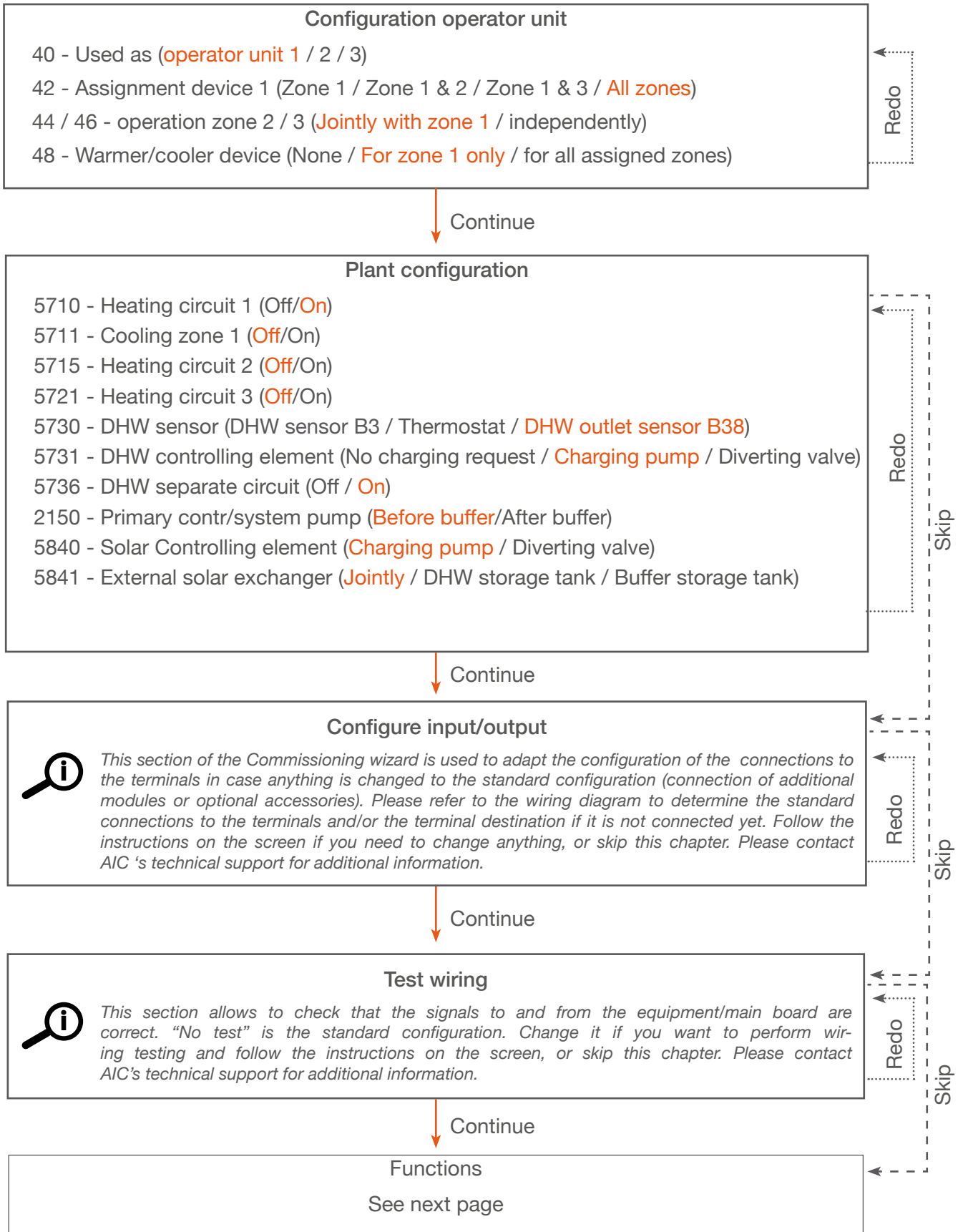

**Functions**

Heating zone 1

- 720 - Heating curve slope (1.50)
- 721 - Heating curve displacement (0°C)
- 730 - Summer-winter heating limit (18°C)
- 732 - 24-hour heating limit (-3°C)
- 740 - Flow temp setpoint min (8°C)
- 741 - Flow temp setpoint max (80°C)
- 750 - Room influence (**unused** (0%) to 100%)
- 760 - Room temp limitation (1.0°C)

Domestic Hot Water

- 1612 - Reduced setpoint (40°C)
- 1620 - Release (**24h/day** / Time programs HCs / Time program 4/DHW)
- 1630 - Charging priority (Absolute / Shifting / None / **MC shifting, PC absolute**)
- 1640 - Legionella function (Off / Periodically / **Fixed weekday**)
- 1645 - Legionella function setpoint (65°C)
- 1641 - Legionella function periodically (3)
- 1642 - Legionella function weekday (Monday / Tuesday / Wednesday.../ Sunday)

Consumer circuit 1

Consumer circuit 2

Swimming pool circuit

Solar

 *These sections allow to define the flow temp for different configurations. Follow the instructions on the screen if you need to change anything or skip this chapter. Please contact AIC's technical support for additional information.*



↓ Continue

**System setup**

LPB system

- 6600 - Device address (**1**....16)
- 6601 - Segment address (**0**...14)
- 6640 - Clock mode (**Autonomously** / Slave without remote setting / Slave with remote setting / Master)

Modbus

- 6651 - Slave address (**unused** (0) ... 247)
- 6652 - Baud rate (1 200 / 2 400 / 4 800 / 9 600 / **19 200**)
- 6653 - Parity (**Even** / Odd / None)
- 6654 - Stop bit (**1** / 2)



↓ Continue

Secure  
See next page



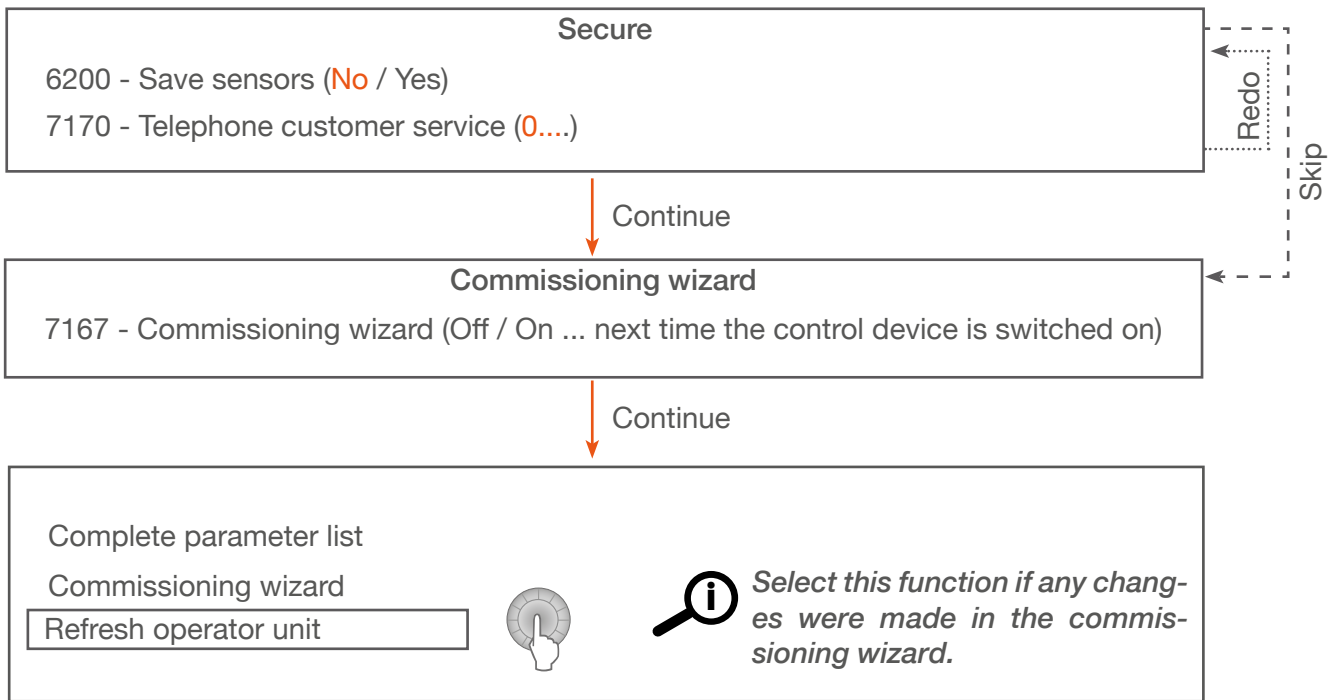

 When performing the setup of the boiler, also refer to "Quick access to functions for the Installer" on page U-74 and to "Weather Compensation Curve" on page U-72.

## Safety Instructions for Maintenance



- › Inspection and maintenance tasks must be carried out by a qualified and certified professional, at least once a year.
- › Water flowing out of the drain valve can be extremely hot. Use extreme caution when draining a hot appliance.
- › Once the inspection and maintenance tasks are complete, ensure that all removed components are reinstalled and all connections are tight and secured.



- › Before performing any maintenance operation, shut down the appliance using the appliance on/off switch and isolate the electrical supply of the appliance through the external power-cutting device (fuse, circuit-breaker, etc.), unless power is required for the procedure (it will then be indicated in the procedure).
- › Do not touch the appliance with any wet body parts when it is supplied with electrical power.
- › Be careful ! Even when the appliance on/off switch is set to OFF, the high voltage terminals are still supplied with electrical power.



- › The maintenance of the appliance and its components must be carried out by a qualified professional.
- › Defective parts and components may only be replaced by genuine factory parts or parts approved by the manufacturer.
- › Replace any gaskets or seals present on the removed components before reinstallation, unless otherwise specified in the procedures.
- › To ensure the performance, durability and reliability of the appliance, it is recommended that the end-user perform the periodic checks mentioned in the Safety section for the user, at the beginning of this manual.
- › The minimum pressure of the primary circuit is 1,2 bar when cold, the normal pressure is 1,2 to the maximum pressure, as defined in the hydraulic characteristics in this manual.
- › If the water circuit needs to be topped up, allow the appliance to cool down and only add small quantities of water at a time. Adding a large quantity of cold water in a hot appliance can damage the appliance permanently.



*The inspection and maintenance tasks are detailed in a table in this section. Make sure to perform all the recommended tasks and to fill in the log sheets available at the end of the manual with all the required information.*



*In this section, the pictures show a specific appliance, but the removal principle is identical for all Nesta Chrome models.*

## Maintenance Requirements

Tasks	@ inspection (1 year)	@ maintenance (2 years max)
Check that the boiler room ventilation / boiler air and flue ducts are unobstructed.	X	X
Verify flue gas and combustion air ducts are in good condition, sealed tight and properly supported.	X	X
Open the front panel and check the general condition inside the cabinet. Clean and vacuum as required.	X	X
Check the correct operation of the flue pressure switch, refer to <b>“Checking the Flue Pressure Switch operation” on page U-68</b>	X	X
Clean the condensate trap. Remove condensate trap and flush with clear water, see <b>“Installing and Removing the Condensate Trap” on page U-29</b>	X	X
Clean/service the condensate neutralisation system (if any). Refer to manufacturer’s documentation.	X	X
Clean any filter/dirt separator, plate heat exchanger or balance header present in the hydraulic system, as required. Refer to manufacturer’s documentation.	X	X
Check for leaks, both inside and outside the appliance: water, gas, flue and condensate.	X	X
Check boiler water pressure (at least 1.2 bar when cold). Top up the system with water if required.	X	X
Check the operation of the burner (flame) through the sight glass and that the combustion parameters (CO & CO <sub>2</sub> ) are according to requirements. See <b>“Combustion Data” on page G-15.</b>	X	X
Check the gas pressure and that the gas supply shut-off devices are operating properly.	X	
Check that the pump(s) is/are operating properly.	X	
Check that the fan is operating properly.	X	
Remove the burner and check its general condition. Clean as required. See <b>“Removing and Installing the Burner” on page U-66.</b>		X
Replace the ignition and ionization electrodes. Refer to <b>“Removing and Installing the Ignition and Ionisation Electrodes” on page U-63.</b>		X
Check all control wiring and connections.	X	X
Check the condition of the combustion chamber and clean it if required. See <b>“Checking and Cleaning the Combustion Chamber” on page U-68.</b>		X
Check water quality and record in log sheet, See <b>“Water Parameters - Log Sheet” on page U-90</b>	X	X
Check the operation of the flue damper (non-return valve), if any, and perform the required maintenance. Refer to the manufacturer’s documentation.	X	X
Record the operations and results in the Log Sheets provided at the end of the manual	X	X

# MAINTENANCE

## Shutting Down for Maintenance

### Conditions:

None

### Procedure:

1. Press the On/Off switch located on the right side of the control panel.

 When in the OFF position, the switch internal light comes out.





2. To completely cut the power supply to the boiler, either disconnect the power supply cable from the boiler, or use the external circuit breaker.

**Follow-on tasks:**   

## Draining the Boiler

**Conditions:**   

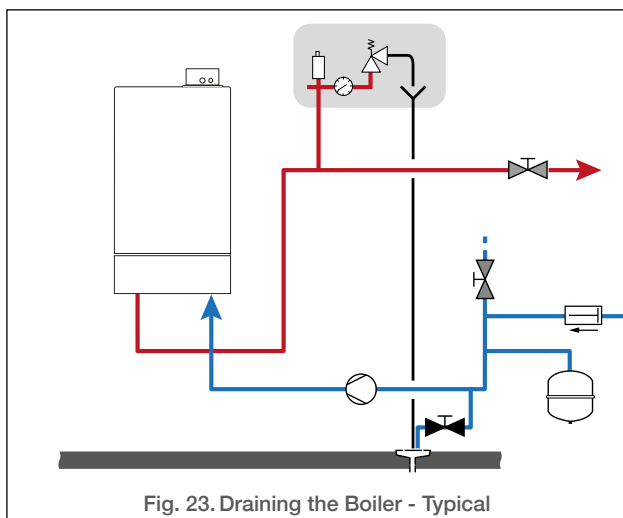

### Procedure:

1. Close the isolating valves .
2. Connect the optional draining valve  to the sewer with a hose.
3. Open the draining valve  to empty the heating circuit of the boiler.
4. Provide relief at the manual air vent of the boiler.
5. Close the draining valve  once the heating circuit of the boiler is empty.



**Follow-on tasks:** None

## Restarting after Maintenance

**Conditions:**    

### Procedure:

1. Press the On/Off switch located on the right side of the control panel.

 The switch is illuminated when in ON position.

2. Select the required heating mode as required.
3. Activate the DHW mode as required.
4. Allow the appliance to operate for a few minutes, then bleed the air from the system.

### Follow-on tasks:

1. Check there is no leak in the water and gas circuits.
2. Check the combustion values according to **“Combustion Data” on page G-15.**
3. Record values in **“Combustion Parameters - Log Sheet” on page U-89.**
4. Check the heating circuit pressure (between 1,2 and 6 bar).

## Removing and Installing the Ignition and Ionisation Electrodes

### Conditions:



### Tools and material:

- Wrench, hex head, size 3
- Torque wrench

### Removal Procedure:

1. Disconnect all connectors and grounding cables from the electrodes.



- *The procedure is identical for both electrodes.*
- *When removing the electrodes in the scope of the periodic maintenance, the electrodes and their gasket must be discarded and replaced by new ones*

2. Release two screws (1) from the electrode flange.
3. Remove the electrode and screws from the burner plate (3). Discard, as required.
4. Remove electrode gasket (2) and discard, as required.

### Installation procedure:

1. Install new gasket (2) on the burner plate (3).
2. Insert the electrode and fasten with 2 screws (1).
3. Torque screws at 2,5 Nm.
4. Reconnect all connectors and grounding cables to the electrodes.

### Follow-on tasks:

1. Reinstall all removed access panels, refer to **“Removing and Installing the Front Panel” on page U-30**
2. Restart the appliance, see **“Restarting after Maintenance” on page U-62.**

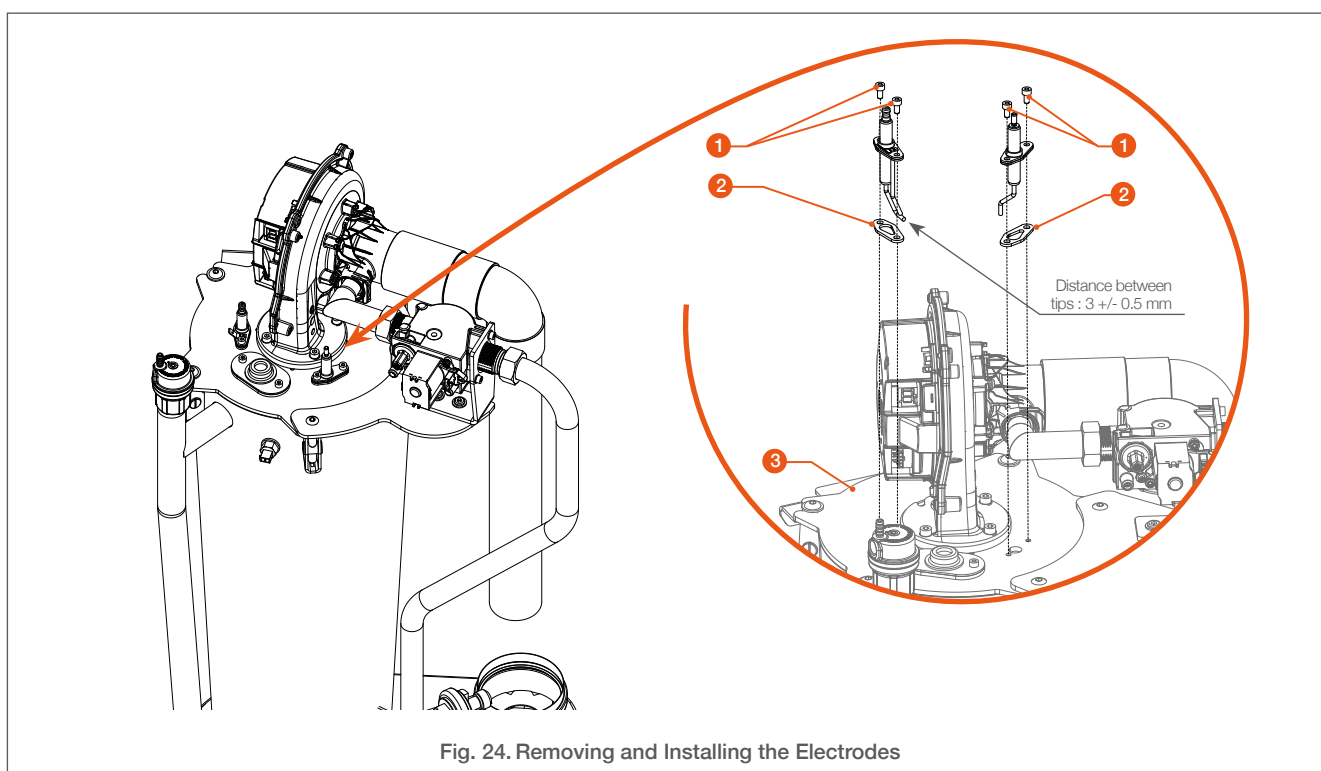

Fig. 24. Removing and Installing the Electrodes

## MAINTENANCE

### Removing and Installing the Fan and Air-Gas Mixer Assembly



#### Tools and material:

- › Wrench, hex head, size 5
- › Wrench, flat
- › Torque wrench

#### Removal Procedure:

1. Disconnect all connectors and ground wires from the electrodes, the fan and the gas valve.
2. Disconnect the air inlet duct (1) from the air-gas mixer (7).
3. Release gas pipe elbow connection (2) from the gas valve (3) and the air-gas mixer (7). Retain gasket and orifice, if installed, with elbow for reinstallation.
4. Release four screws and washers (4) securing the fan assembly (5) to the burner plate.
5. Remove the assembly (5) formed by the fan, and the air-gas mixer. Retain for reinstallation.
6. Remove the fan gasket (6) and retain, as required, for reinstallation.



*When removing the gasket, check its general condition. Discard and replace the gasket if it is cracked or torn.*

7. Remove the electrodes, as required, refer to **“Removing and Installing the Ignition and Ionisation Electrodes” on page U-63.**
8. Remove the burner, as required, refer to **“Removing and Installing the Burner” on page U-66.**
9. Clean the combustion chamber, as required, refer to **“Checking and Cleaning the Combustion Chamber” on page U-68.**

#### Installation Procedure:

1. Install the fan assembly (5) with a new gasket (6) (if required) on the burner plate, using four retained screws and washers (4).
2. Torque the screws (4) at 4 Nm.
3. Connect gas pipe elbow connection (2) to the air-gas mixer (7).
4. Before connecting the gas pipe elbow connection (2) to the gas valve (3), check the condition of the gasket. Install a new one if it is cracked or damaged.
5. Install the (new) gasket, and propane orifice if previously removed, and connect gas pipe elbow connection (2) to the gas valve (3). Torque at 20 Nm.
6. Connect the air inlet duct (1) to the air-gas mixer (7).
7. Reconnect all connectors to the electrodes, gas valve and fan.

#### Follow-on task(s):

1. Close all panels, refer to **“Removing and Installing the Front Panel” on page U-30.**
2. Restart the boiler, as required, refer to **“Restarting after Maintenance” on page U-62.**



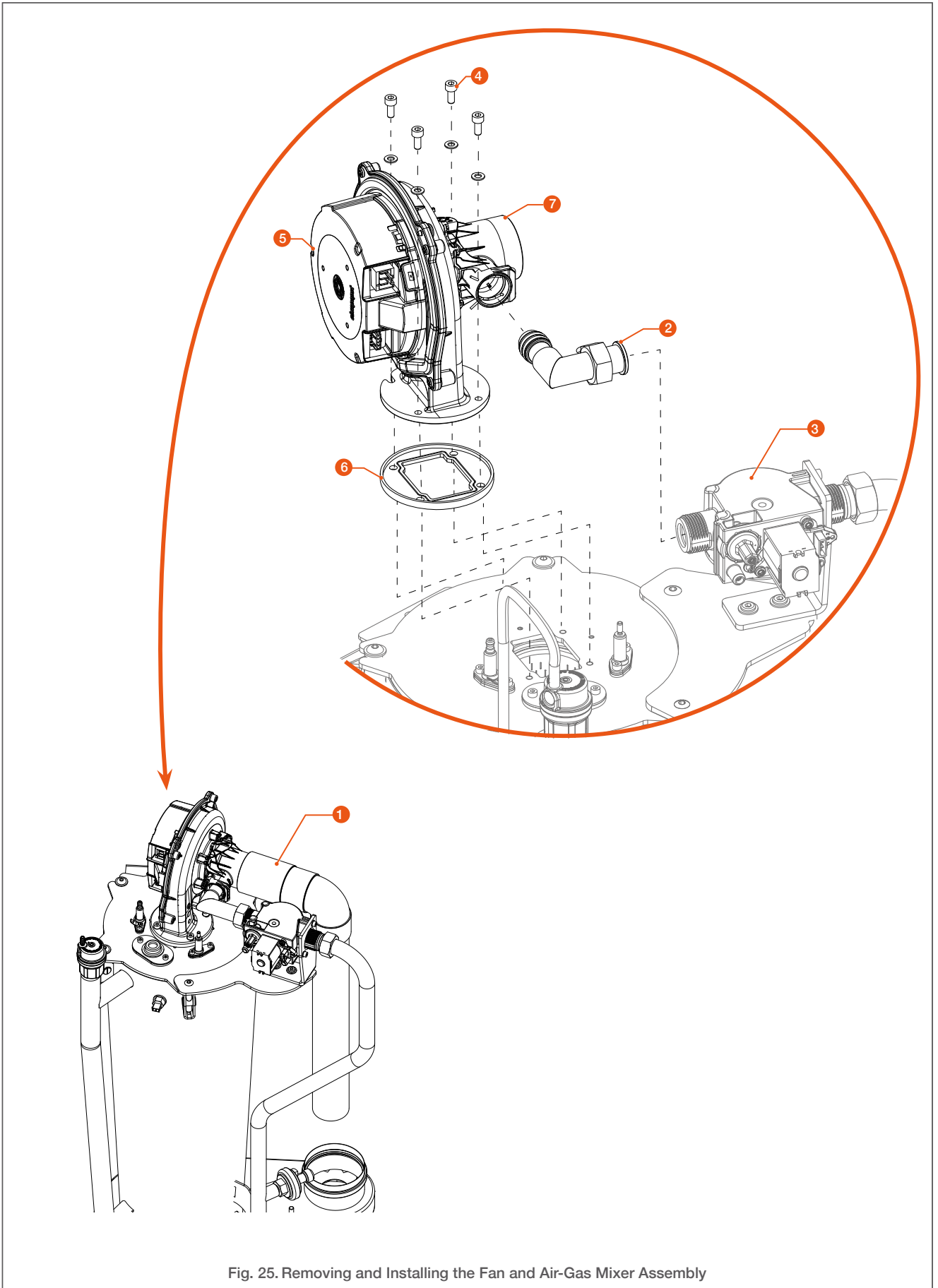

Fig. 25. Removing and Installing the Fan and Air-Gas Mixer Assembly

### Removing and Installing the Burner

**Conditions:**     

- ▶ Fan and air-gas mixer assembly removed, refer to **“Removing and Installing the Fan and Air-Gas Mixer Assembly” on page U-64.**
- ▶ Electrodes removed, refer to **“Removing and Installing the Ignition and Ionisation Electrodes” on page U-63**

#### **Tools and material:**

- ▶ Wrench, hex head, size 3
- ▶ Torque wrench
- ▶ Air compressor

#### **Removal Procedure:**

1. Release union (6) and disconnect the gas pipe (7) from the gas valve (8).
2. Release two screws (10) securing the gas pipe bracket (9) to the burner plate (1).
3. Remove and retain the gas valve and bracket assembly (9) and hardware for reinstallation.
4. Release the remaining screws (10) securing the burner plate (1). Remove the burner plate (1) and hardware. Retain for reinstallation.
5. Remove four screws and washers (5) to remove the burner tube (3) and gasket (2) from the burner plate. Discard the gasket.
6. Remove carefully the burner plate insulation plate (4).

#### **Cleaning and Checks:**

1. Visually check the condition of the burner tube (3).
2. Clean with compressed air to remove residues. If it is in bad condition after cleaning, replace it.
3. Visually check the condition of the burner plate insulation plate (4). If the fabric cover is damaged, replace the insulation plate.
4. Clean the combustion chamber, see **“Checking and Cleaning the Combustion Chamber” on page U-68.**

#### **Installation procedure:**

1. Install the burner plate insulation plate (4).
2. Install burner tube (3) and new gasket (2) on burner plate (1) using four retained screws and washers (5).
3. Position burner plate (1) on heat exchanger and secure with three retained screws (10).
4. Install the bracket and gas valve assembly (9) on burner plate (1) and secure with two retained screws.
5. Torque all the screws burner plate screws (10) in a crosswise pattern at 5 to 6 Nm.
6. Secure the gas valve (8) to the gas pipe (7) with union (6).

#### **Follow-on tasks:**

1. Reinstall the fan and air-gas mixer assembly, refer to **“Removing and Installing the Fan and Air-Gas Mixer Assembly” on page U-64**
2. Reinstall all removed access panels, refer to **“Removing and Installing the Front Panel” on page U-30.**
3. Restart the boiler, see **“Restarting after Maintenance” on page U-62.**

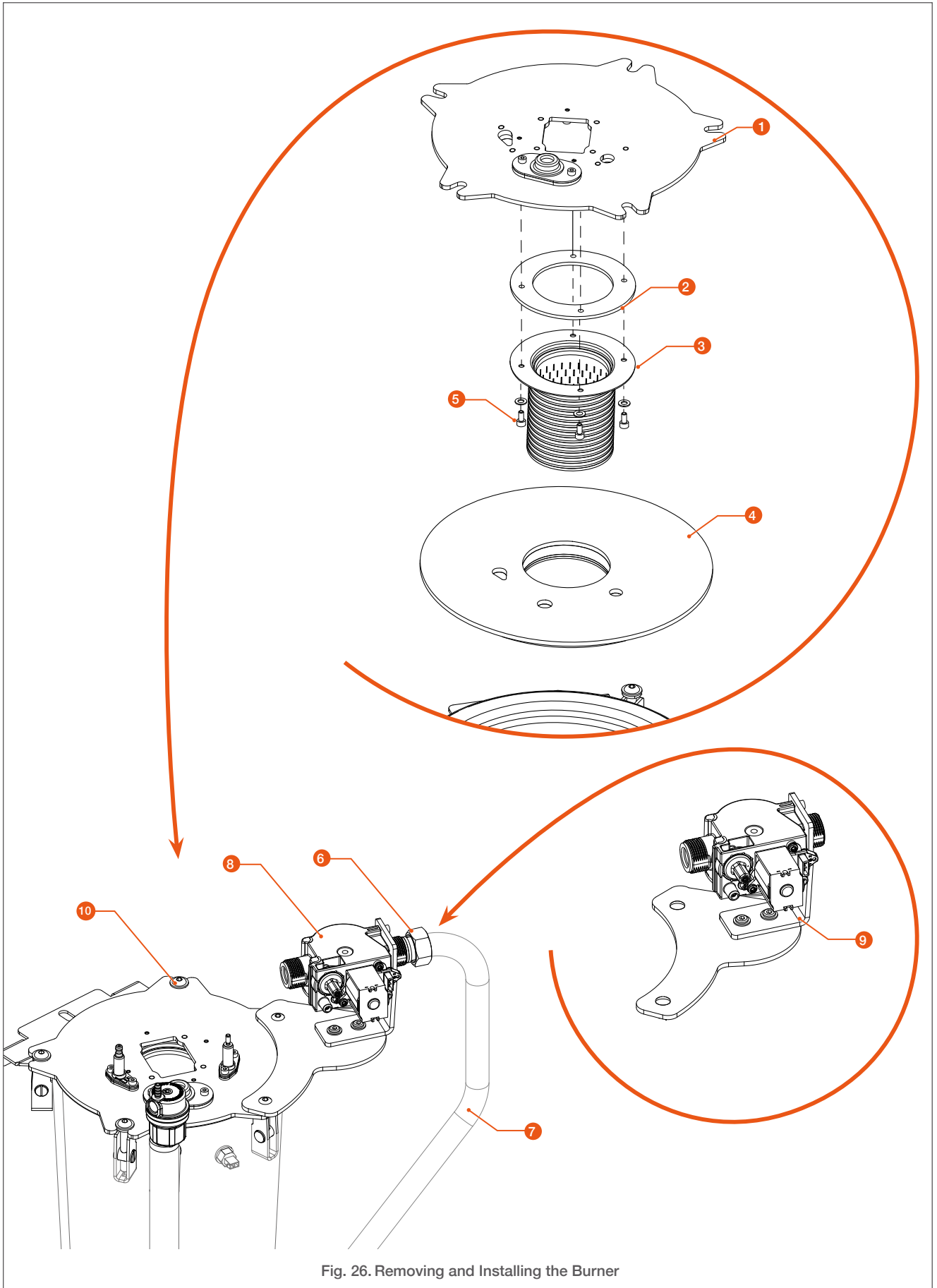

Fig. 26. Removing and Installing the Burner

## MAINTENANCE

### Checking and Cleaning the Combustion Chamber

Conditions:



- › Burner removed, see *“Removing and Installing the Burner”* on page U-66.

#### Tools and material:

- › Industrial vacuum cleaner
- › Nylon bristle brush
- › Torch

#### Check Procedure:

1. Using a torch, visually check the condition of the combustion chamber. If it is dirty, clean it.

#### Cleaning Procedure:

1. Using a nylon bristle brush, sweep the walls of the combustion chamber.
2. Using an industrial vacuum cleaner, remove all deposits from the combustion chamber heating surfaces.
3. Pour some clean water to remove any residues.

#### Follow-on tasks:

1. Remove and clean condensate trap, refer to *“Installing and Removing the Condensate Trap”* on page U-29
2. Install the burner, see *“Removing and Installing the Burner”* on page U-66.

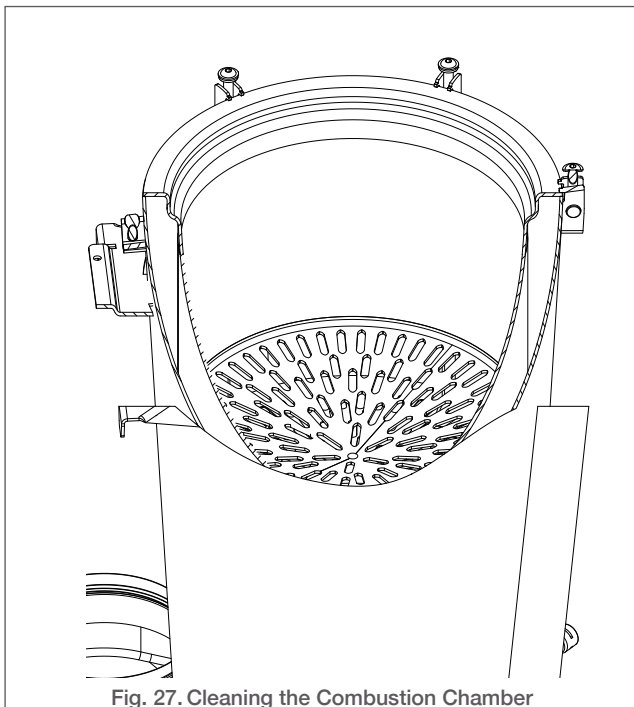

Fig. 27. Cleaning the Combustion Chamber

### Checking the Flue Pressure Switch operation

Conditions:



#### Tools and material:

- › Manometer (measuring range up to min 500 Pa)

#### Check Procedure:



**This procedure needs to be performed with boiler (and controller) running, and the front panel open.**



**When performing the following procedure, do not touch the high voltage connections and do not touch any inner component of the boiler with any wet body part.**

1. At the condens dish (2), disconnect the hose running to the flue pressure switch (1).
2. Connect a T-piece to the hose.
3. Connect pressure meter to one of the T-piece connections.
4. Blow air into the hose while it is connected to the flue pressure switch and to the manometer.
5. Verify that the pressure switch switches at the set pressure (400 Pa) and that the controller displays an error (refer to *“Error Codes and Solutions”* on page U-78).
6. In case of malfunction, replace the flue pressure switch.

#### Follow-on tasks:

1. Reconnect the hose to the condens dish (2).
2. Check that the connection is not leaking.

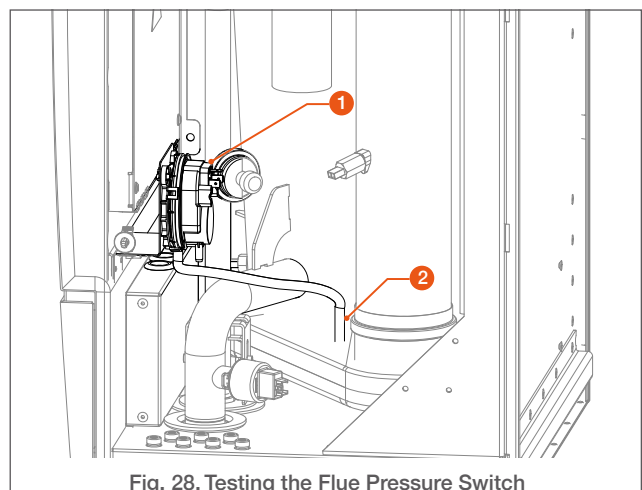

Fig. 28. Testing the Flue Pressure Switch

## Optional Accessories

### Extension Modules

Nesta Chrome boilers can control **several** heating circuits with mixing functions, using 1 extension module. The extension supply needs to be provided with power supply and a bus connection.

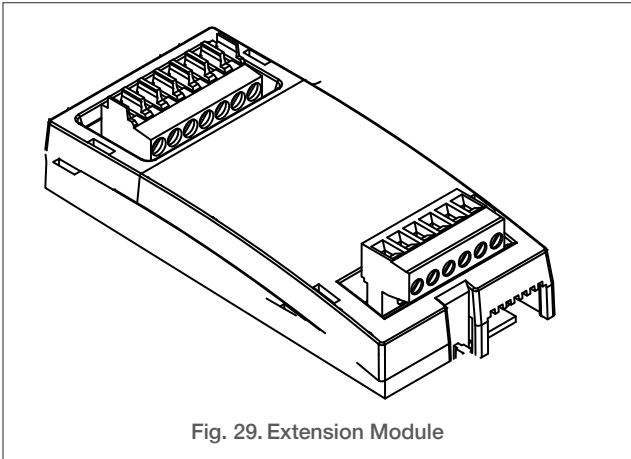

Fig. 29. Extension Module

### Cascade module

This module allows the installation of several boilers in a cascade to increase the heating power in specific applications. This cascade module enables communication from one boiler to another, and must be installed in each boiler. See ***“Boilers in a Cascade System”*** on page U-70.

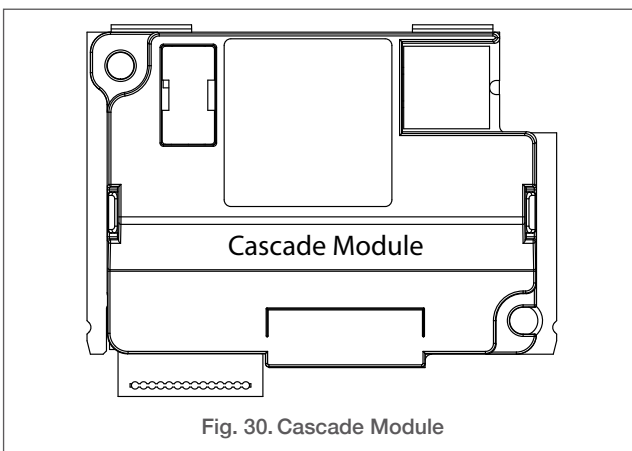

Fig. 30. Cascade Module

### Web Server Module

Through the use of this module, you can connect to an Ethernet and get remote access to the boiler and all the heating system via the Internet. Using a computer or mobile devices, you can monitor and control the installation remotely. Management takes place via a web browser.

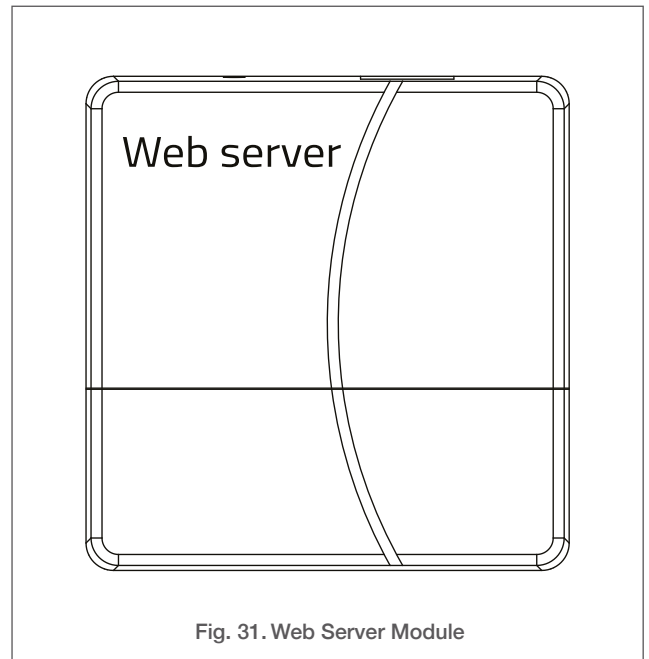

Fig. 31. Web Server Module

### Hydraulic kits

Two hydraulic kits, with one or two pumps, are available for this appliance. Please contact your AIC representative for more information.

## Boilers in a Cascade System

In a heating system comprised of several boilers, it is important that the power generated by the boilers adapts at any moment to the demand of the installation, always optimising the generators' efficiency.

Up to 4 boilers can be connected in a cascade to one chimney, and 4 such groups of boilers with their chimneys can be controlled using the control unit of one boiler.

The boiler with device address 1 assumes the role of the cascade Principal, and the others are Subsequent.

 *In the controller menus, please note that the Principal boiler is called "Master" and a Subsequent boiler is called "Slave".*

The principal boiler activates the required functions and shows the additional menus with the parameters for use with the cascaded system.

This boiler has all the logic control of the cascaded system and also regulates the stop/start sequence of each boiler according to the demand of the installation.

The boilers are connected with each other using the cascade module (see Fig. 33). Each boiler has its own module, which is connected directly to the board.

When several boilers are cascaded through their chimney system, make sure to install a non-return valve (flue damper) between the boiler flue outlet and the chimney connection. This will prevent any back flow of the flue gases into a boiler that is not in operation. Please refer to the manual provided with the accessory for installation and maintenance recommendations.

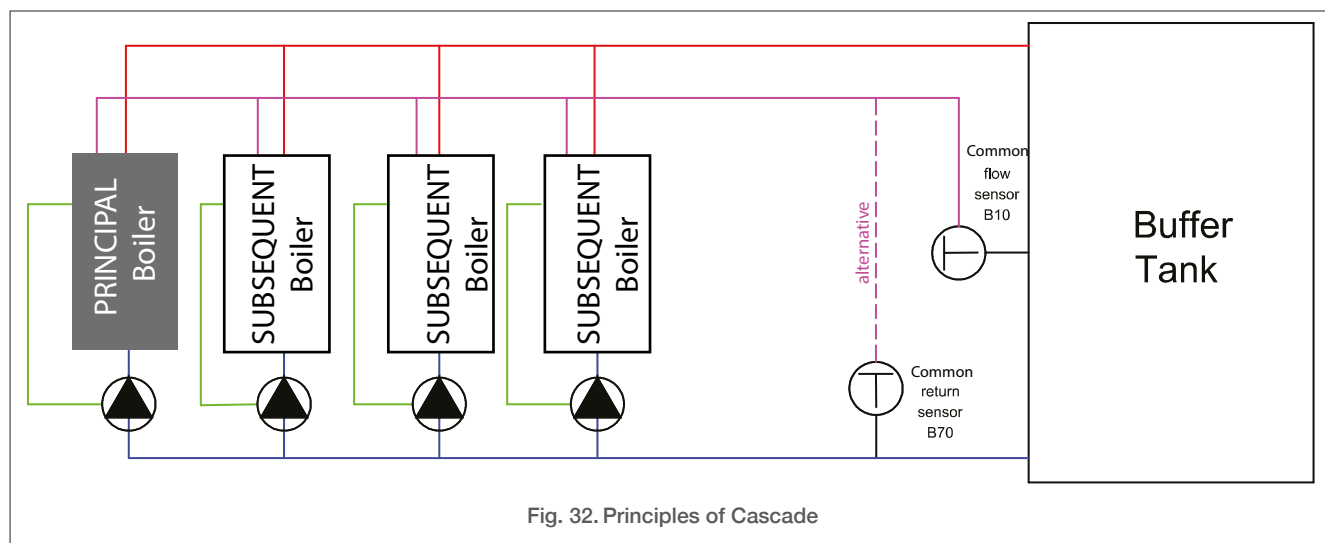

Fig. 32. Principles of Cascade

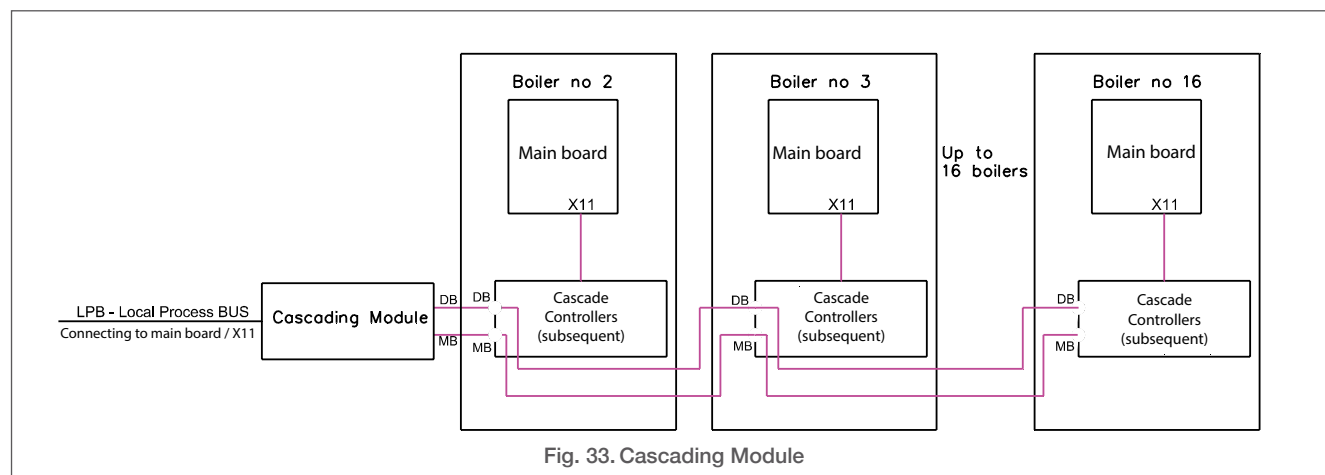
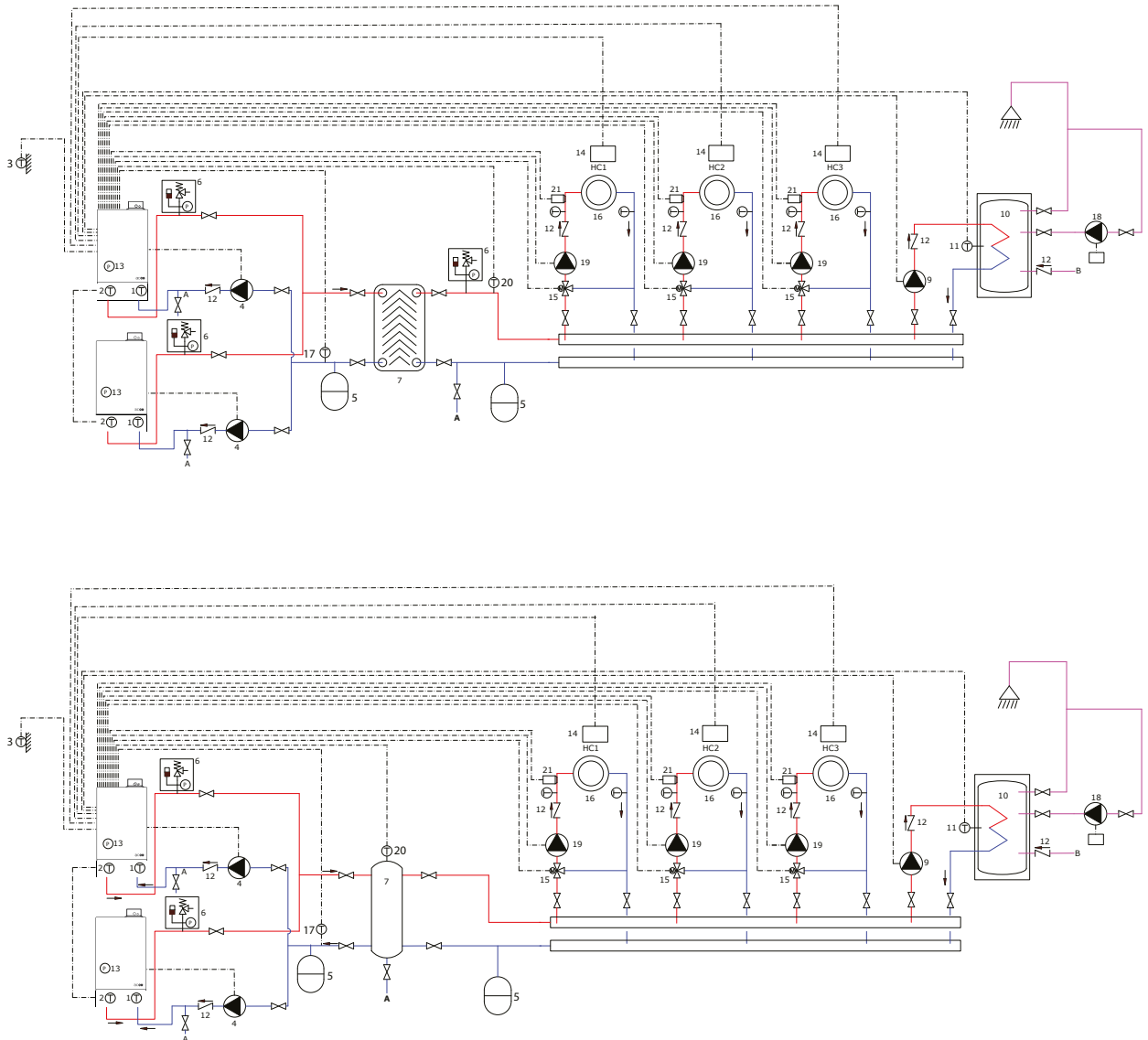

Fig. 33. Cascading Module



- |   |   |
|---|---|
| H.C. – Heating circuit  | 10. DHW Storage tank                    |
| D.H.W. – Domestic hot water                                     | 11. DHW Storage tank temperature sensor |
| A – Mains cold water supply/drain                               | 12. Check valve                         |
| B – DHW cold water supply                                       | 13. Water pressure sensor               |
| 1. Return temperature sensor                                    | 14. Room unit / Room thermostat         |
| 2. Supply temperature sensor                                    | 15. Mixing valve                        |
| 3. Outside temperature sensor                                   | 16. Consumers                           |
| 4. Boiler pump  | 17. Cascade return sensor               |
| 5. Expansion tank   | 18. DHW Circulation pump (with timer)   |
| 6. Safety group (safety valve, air vent - air purge, manometer) | 19. HC Pump                             |
| 7. Plate heat exchanger/Low loss header                         | 20. System supply sensor                |
| 8. Air vent   | 21. HC1, HC2, HC3 temperature sensor    |
| 9. DHW Pump   |   |

Fig. 34. Cascade System with Plate Heat Exchanger / Low Loss Header

## Weather Compensation Curve

The heating curve generates the flow temperature setpoint (program lines 720, 1020 and 1320 for HC1 to HC3), which is used to maintain a certain flow temperature level depending on the prevailing weather conditions. The heating curve can be adjusted in different ways, thus matching the heat output and the room temperature to individual needs.

When the heating curve slope is raised, the flow temperature increases as the outside temperature drops. Or, in other words, if the room temperature is not correct at low outside temperatures but correct at higher outside temperatures, the heating curve slope must be readjusted.

**Increasing the slope:** Raises the flow temperature, especially when the outside temperature is low.

**Decreasing the slope:** Lowers the flow temperature, especially when the outside temperature is low.



*The set heating curve is based on a room temperature setpoint of 20 °C. If this setpoint is changed, the heating curve adapts automatically to the new value*

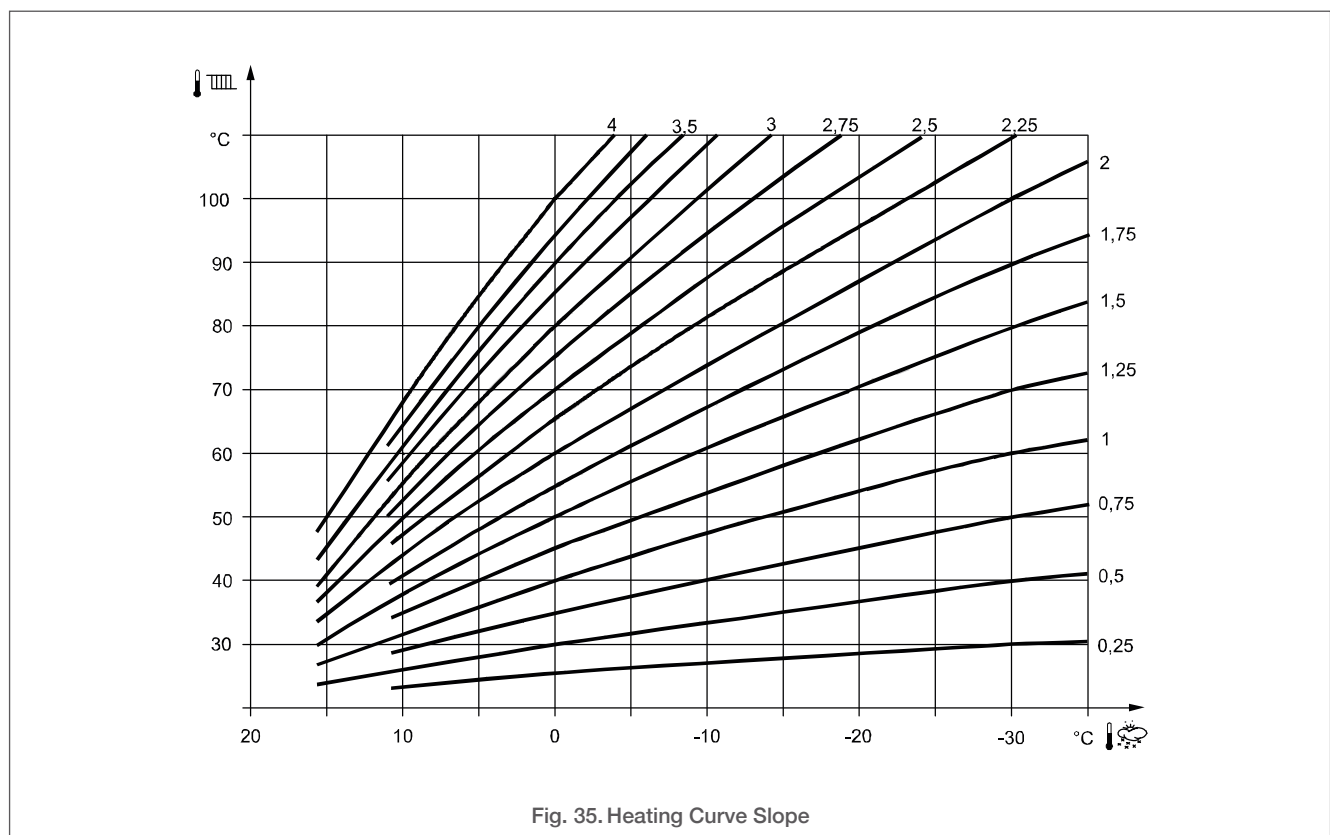

Fig. 35. Heating Curve Slope



## Boiler Settings for the Installer

### Access Levels

Three different levels of settings are available for the Installer : End user level, Commissioning level and Engineer level. A fourth level, OEM, is only accessible at factory level, through the use of a code.

Each level allows to set certain specific parameters or program the boiler, according to the installed circuits.

The menus of the End user level are described in **“Operating the Controller - End User Level” on page U-21**. The menus for the qualified professional (Commissioning and Engineer) are described in the following pages.



To access the Commissioning and the Engineer levels, proceed as follows:

### Menus and Settings

The following table contains some of the menus and submenus for the installer. The last column allows the installer to write down the setting defined for each parameter at installation, if it is different from the default.

For any question related to the menus, please contact AIC’s technical support.

Symbols used for the **operation of the selector**:

-  turn the selector to the left or to the right.
-  depress shortly the rotary selector.
-  turn the selector to adjust the value, then depress the selector to validate.



- ▶ The process is identical to access the commissioning level.
- ▶ In some recently manufactured products, a password may be required to access the Engineer level and the login will be indicated as unsuccessful if you do not enter it. In that case, please contact your AIC representative for more information.

### Selecting the User Level & Accessing the Complete Parameter List

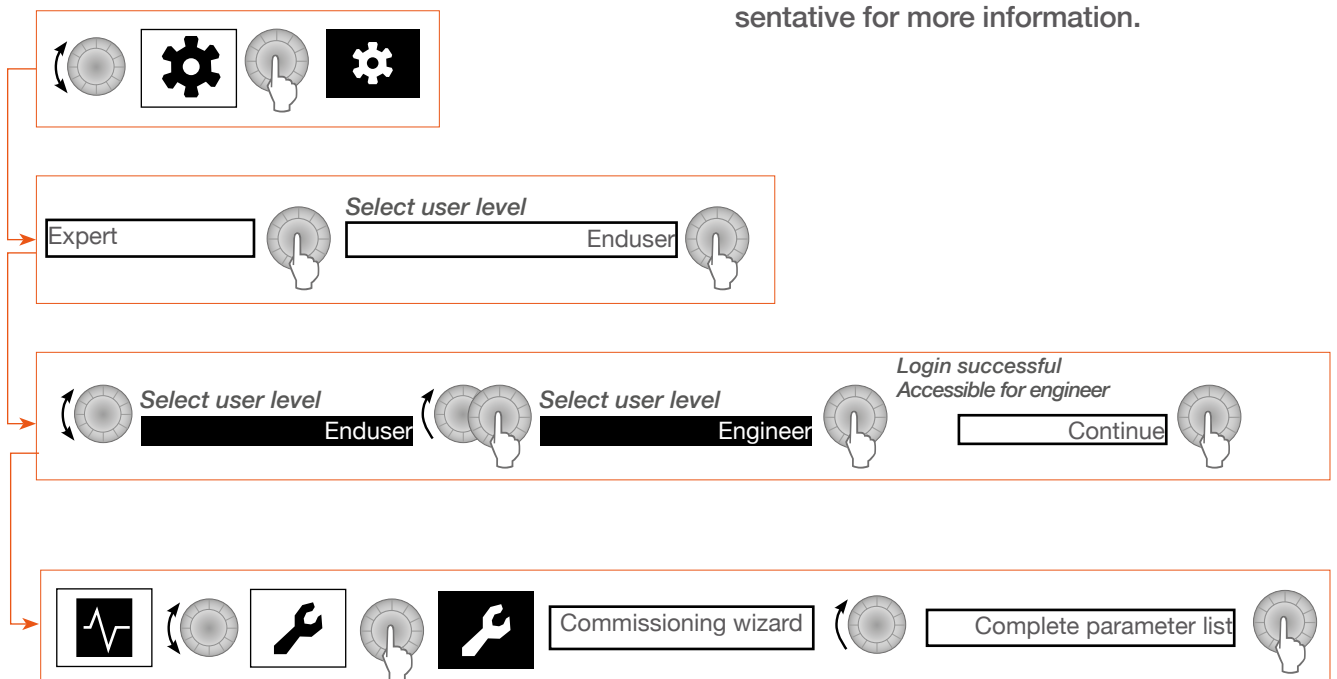

Quick access to functions for the Installer

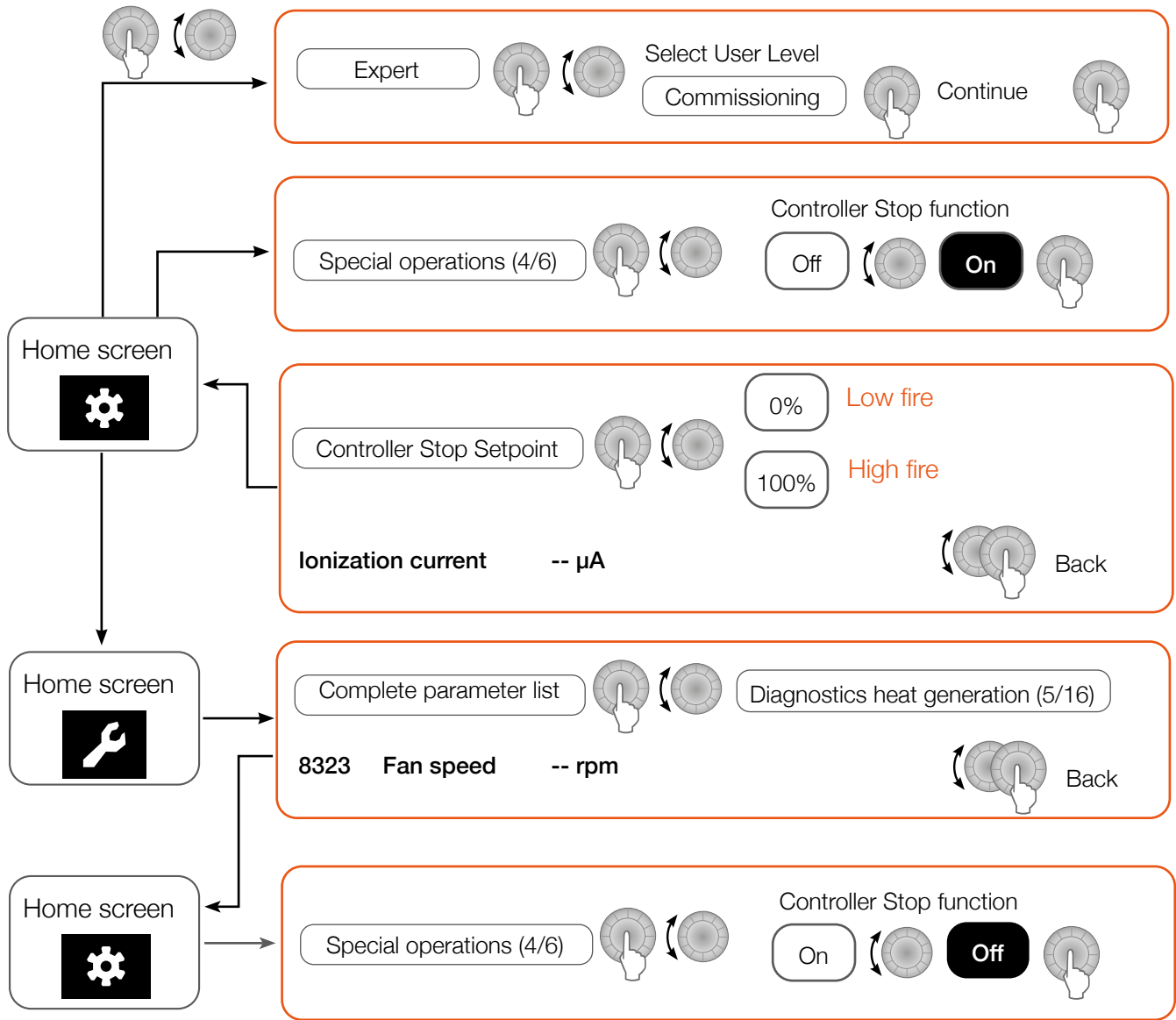

Setting to Low/High Fire - Reading Ionization current and fan speed

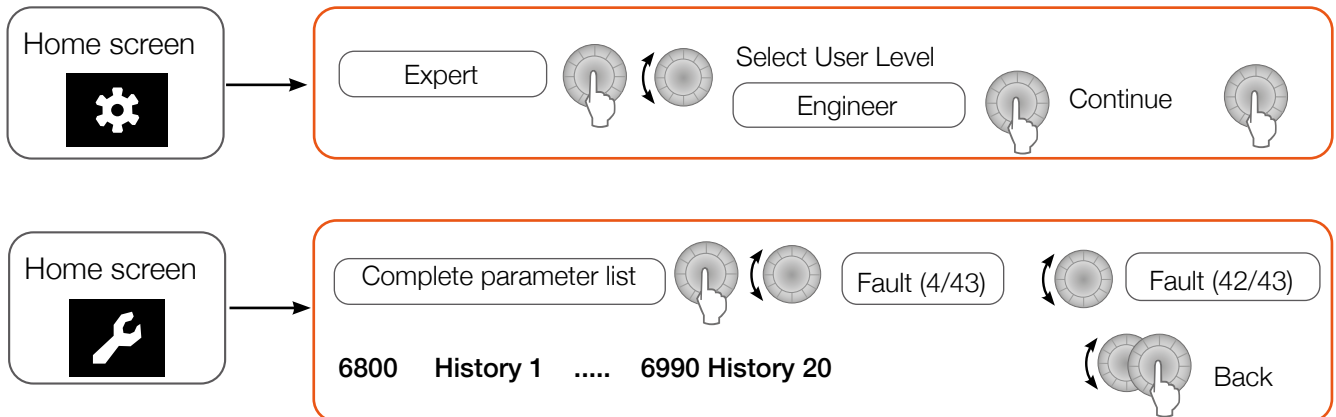

Reading the Error History



Structure of Menus for the Installer

Top menu	page	Pgm No.	Submenu 1	Submenu 2	Default	Setting
<b>Time of day and date</b> (2 pages)	p. 1/2	1	▶ Hours / Minutes		01:00 (hh:min)	
		1	▶ Date		01.01.2030 (dd.mm.yyyy)	
	p. 2/2	5	▶ Start of summertime		25.03 (dd.mm)	
		6	▶ End of summertime		25.10 (dd.mm)	
<b>Operator section</b> (3 pages)	p. 1/3	20	▶ Language	English - Deutsch - Français - Italiano - Nederlands - Español - Portuguese - Dansk - Suomi - Svenska - Polski - Slovensky - Český - Slovenščina - русский - Magyar - Ελληνικά - Türkçe - Serbian - Lietuvių	English	
		40	▶ Used as	• Operator unit 1 • Operator unit 2 • Operator unit 3	Operator unit 1	
		42	▶ Assignment device 1	• Zone 1 • Zone 1 and 2 • Zone 1 and 3 • All zones	All zones	
	p. 2/3	44	▶ Operation HC2	• Jointly with zone 1 • Independently	Jointly with zone 1	
		46	▶ Operation HC3/P	• Jointly with zone 1 • Independently	Jointly with zone 1	
		48	▶ warmer/cooler device 1	• None • For zone 1 only • For all assigned zones	For zone 1 only	
	p. 3/3	70	▶ Software version			
<b>Time Prog heating circuit 1</b>		—	▶ Set time program		Refer to "Basic Settings" on page U-24	
		516	▶ Default values	• No • Yes	No	
<b>Time Program 5</b>		—	▶ Set time program		Refer to "Basic Settings" on page U-24	
		616	▶ Default values	• No • Yes	No	
<b>Heating circuit 1</b> (16 pages)	p. 1/16	710	▶ Comfort setpoint		20.5°C	
		712	▶ Reduced setpoint		16.0°C	
		714	▶ Frost protection setpoint		10.0°C	
	p. 2/16	716	▶ Comfort setpoint max		35.0°C	
		720	▶ Heating curve slope		1.5	
		721	▶ Heating curve displacement		0.0°C	
	p. 3/16	726	▶ Heating curve adaptation	• Off • On	Off	
		730	▶ Summer/winter heating limit		18.0°C	
	732	▶ 24-hour heating limit		-3°C		

## ADDITIONAL INFORMATION FOR THE INSTALLER

Top menu	page	Pgm No.	Submenu 1	Submenu 2	Default	Setting
Heating circuit 1 (Ctn'd)	p. 4/16	733	▶ Ext'n 24-hour heating limit	<ul style="list-style-type: none"> <li>• No</li> <li>• Yes</li> </ul>	Yes	
		740	▶ Flow temp setpoint min		8°C	
		741	▶ Flow temp setpoint max		80°C	
	p. 5/16	742	▶ Flow temp setpoint room stat		65°C	
		744	▶ Swi-on ratio room stat		---	
		746	▶ Delay heat request		0 s	
	p. 6/16	750	▶ Room influence		Unused	
		760	▶ Room temp limitation		1°C	
		761	▶ <b>Heating limit room controller</b>		---	
	p. 7/16	770	▶ Boost heating		5°C	
		780	▶ Quick setback	<ul style="list-style-type: none"> <li>• Off</li> <li>• To reduced setpoint</li> <li>• To frost prot setpoint</li> </ul>	To reduced setpoint	
		790	▶ Optimum start control max		0 min	
	p. 8/16	791	▶ Optimum stop control max		0 min	
		800	▶ Reduced setp increase start		Unused	
		801	▶ Reduced setp increase end		-15°C	
	p. 9/16	809	▶ Continuous pump operation	<ul style="list-style-type: none"> <li>• No</li> <li>• Yes</li> </ul>	No	
		820	▶ Overtemp prot pump circuit	<ul style="list-style-type: none"> <li>• Off</li> <li>• On</li> </ul>	On	
		830	▶ Mixing valve boost		5°C	
	p. 10/16	832	▶ Actuator type	<ul style="list-style-type: none"> <li>• 2 position</li> <li>• 3 position</li> </ul>	3 position	
		833	▶ Switching differential 2-pos		2°C	
834		▶ Actuator running time		120 s		
p. 11/16	835	▶ Mixing valve Xp		32°C		
	836	▶ Mixing valve Tn		120s		
	850	▶ Floor curing function	<ul style="list-style-type: none"> <li>• Off</li> <li>• Functional heating</li> <li>• Curing heating</li> <li>• Curing/Functional heating</li> <li>• Functional/Curing heating</li> <li>• Manually</li> </ul>	Off		
	851	▶ Floor curing setp manually		25°C		
	855	▶ Floor curing setp current		---		
p. 12/16	856	▶ Floor curing day current		---		
	861	▶ Excess heat draw	<ul style="list-style-type: none"> <li>• Off</li> <li>• Heating mode</li> <li>• Always</li> </ul>	Always		
	870	▶ With buffer	<ul style="list-style-type: none"> <li>• No</li> <li>• Yes</li> </ul>	Yes		
p. 13/16	872	▶ With prim contr/system pump	<ul style="list-style-type: none"> <li>• No</li> <li>• Yes</li> </ul>	Yes		
	880	▶ Pump speed reduction	<ul style="list-style-type: none"> <li>• Operating level</li> <li>• Characteristic</li> <li>• Temp differential nominal</li> </ul>	Characteristics		
	881	▶ Starting speed		100%		
p. 14/16	882	▶ Pump speed min		50%		
	883	▶ Pump speed max		100%		
	888	▶ Curve readj. at 50% speed		33%		
	889	▶ Filter time const speed ctrl		5 min		
	p. 15/16					
Heating circuit 1 (Ctn'd)	p. 15/16					

## ADDITIONAL INFORMATION FOR THE INSTALLER

Top menu	page	Pgm No.	Submenu 1	Submenu 2	Default	Setting
	<i>p. 16/16</i>	890	▶ Flow setp readj speed ctrl	<ul style="list-style-type: none"> <li>• No</li> <li>• Yes</li> </ul>	Yes	
		898	▶ Operating level changeover	<ul style="list-style-type: none"> <li>• Frost protection</li> <li>• Reduced</li> <li>• Comfort</li> </ul>	Reduced	
		900	▶ Optg mode changeover	<ul style="list-style-type: none"> <li>• None</li> <li>• Protection</li> <li>• Reduced</li> <li>• Comfort</li> <li>• Automatic</li> </ul>	Protection	
<b>Boiler</b>		2214	▶ Setpoint manual control		60°C	
<b>Fault</b>		6705	▶ SW Diagnostic code			
		6706	▶ Burn ctrl phase lockout pos			
<b>Service/ special operation</b> (8 pages)	<i>p. 3/8</i>	7130	▶ Chimney sweep function	<ul style="list-style-type: none"> <li>• Off</li> <li>• On</li> </ul>	Off	
	<i>p. 4/8</i>	7131	▶ Burner output	<ul style="list-style-type: none"> <li>• Partial load</li> <li>• Full load</li> <li>• Max heating load</li> </ul>	Max heating load	
		7140	▶ Manual control	<ul style="list-style-type: none"> <li>• Off</li> <li>• On</li> </ul>	Off	
<b>Diagnostics heat gener- ation</b>  (20 pages)	<i>p. 9/20</i>	8338	▶ Hours run heating mode			
	<i>p. 10/20</i>	8339	▶ Hours run DHW			
		8378	▶ Total gas energy heating			
	<i>p. 11/20</i>	8379	▶ Total gas energy DHW			
		8380	▶ Total gas energy			
		8381	▶ Gas energy heating	<ul style="list-style-type: none"> <li>• Yes</li> <li>• No</li> </ul>		
	<i>p. 12/20</i>	8382	▶ Gas energy DHW	<ul style="list-style-type: none"> <li>• Yes</li> <li>• No</li> </ul>		
		8383	▶ Gas energy			
	<i>p. 18/20</i>	8526	▶ 24-Hour yield solar energy			
		8527	▶ Total yield solar energy			
		8530	▶ Hours run solar yield			
		8532	▶ Hours run collector pump			
<b>Diagnostics consumers</b>	<i>p. 1/27</i>	8700	▶ Outside temp			
		8701	▶ Outside temp min Reset?			
		8702	▶ Outside temp max Reset?			

## ADDITIONAL INFORMATION FOR THE INSTALLER

### Error Codes and Solutions



Error code	Fault description	Explanation	Action(s)
10	Outside temperature sensor error		Check connection and/or sensor. Replace as required. Emergency operation Contact AIC technical support.
20	Boiler temperature 1, sensor error	Short circuit or Open circuit boiler flow sensor.	Check connection and sensor. Replace as required.
26	Common flow temperature, sensor error	Short circuit or Open circuit common flow temperature sensor.	Check connection and sensor. Replace as required.
28	Flue gas temperature sensor error	Short circuit or Open circuit flue gas sensor.	Check connection and sensor. Replace as required.
30	Flow temperature 1, sensor error	Short circuit or Open circuit flow sensor.	Check connection and sensor. Replace as required.
32	Flow temperature 2, sensor error	Short circuit or Open circuit boiler flow sensor.	Check connection and sensor. Replace as required.
38	Flow temperature, primary controller, sensor error		Check connection and sensor. Replace as required.
40	Return temperature 1, sensor error	Short circuit or Open circuit boiler return sensor.	Check connection and sensor. Replace as required.
46	Cascade return temperature, sensor error		Check connection and sensor. Replace as required.
47	Common return temperature, sensor error		Check connection and sensor. Replace as required.
50	DHW temperature 1 sensor error		Check connection and sensor. Replace as required.
52	DHW temperature 2, sensor error		Check connection and sensor. Replace as required.
54	Flow temperature DHW, sensor error	Short circuit or Open circuit DHW flow sensor.	Check connection and sensor. Replace as required.
57	DHW circulation, sensor error		Check connection and sensor. Replace as required.
60	Room temperature 1, sensor error		Check connection and sensor. Replace as required.
65	Room temperature 2, sensor error		Check connection and sensor. Replace as required.
68	Room temperature 3, sensor error		Check connection and sensor. Replace as required.
70	Storage tank temperature 1 (top), sensor error		Check connection and sensor. Replace as required.
71	Storage tank temperature 2 (bottom), sensor error		Check connection and sensor. Replace as required.
72	Storage tank temperature 3 (center), sensor error		Check connection and sensor. Replace as required.
78	Water pressure, sensor error		Check connection and sensor. Replace as required.

Error code	Fault description	Explanation	Action(s)
81	LPB short circuit or no bus power supply		Check LPB connections and bus power supply.
82	LPB address collision		Check addresses of connected control modules
83	BSB wire cross-sectional/ no communication		Check connection of the room units
84	BSB wire address collision	2 room devices have the same assignment (prog.no. 42)	Correct device address.
85	BSB RF communication error		Check bus connection and components.
91	Data overrun in EEPROM	Internal fault in controller, process sensor	Contact AIC technical support.
98	Extension module 1, error		Check extension module connections.
99	Extension module 2, error		Check extension module connections.
100	2 clock time masters		Check time master
102	Clock time master without backup		Check clock
103	Communication error		Check connection and components
105	Maintenance message		See maintenance code (press information button once) for detailed information
109	Supervision boiler temperature		Contact AIC technical support.
110	STB (SLT) lockout	No heat removal, STB interruption, possible short-circuit in the gas valve, internal fuse faulty; Internal pump malfunction	Allow device to cool down and carry out reset; if the fault occurs several times inform AIC technical support Check the internal pump, water cooled burner plate not properly air-vented
111	Temperature limiter safety shutdown		Contact AIC technical support.
117	Water pressure too high		Release the water to a suitable pressure
118	Water pressure too low		Top up the system with water to reach a suitable pressure
121	Flow temperature heating circuit 1 not reached	Heat losses in circuit	Check the circuit for fault insulation and heat losses.
122	Flow temperature heating circuit 2 not reached	Heat losses in circuit	Check the circuit for fault insulation and heat losses.
125	Maximum boiler temperature exceeded		Contact AIC technical support.
126	DHW charging temperature not reached		Check operation and heat up times for DHW
127	DHW legionella temperature not reached		Check operation of appliance
128	Loss of flame during operation	Ionization current lost after successful ignition	Check electric supply, polarity and ionization electrode, as well as ignition components/parameters.
129	Wrong air supply		Check air supply

## ADDITIONAL INFORMATION FOR THE INSTALLER

Error code	Fault description	Explanation	Action(s)
130	Flue gas temperature limit exceeded	Heat engine is overheating	Check causes of high temps Check connection and sensor. Replace as required Check connection and chimney.
132	Gas pressure switch safety shut down	Lack of gas	Check gas supply and pressure Check connection and component
133	Safety time for establishment of flame exceeded	Lack of gas, Polarity of mains connection, safety period,	Reset, if the fault re-occurs more than 3 times, contact AIC technical support. Check ignition electrode and ionization current
146	Configuration error sensor/controlling elements		Check sensor configuration or replace component
151	LMS14... error, internally		Check parameters (see adjustment table installer and/or call-up values) Reset controller and/or replace as required, Check electrode wiring Contact AIC technical support.
152	Parameterization error	Incorrect / Conflicting parameters input.	Verify parameters or reset to default parameters
153	Unit manually locked	Reset button stuck in	Check reset button
160	Fan speed threshold not reached	Fan/relay possibly defective, speed threshold set wrongly.	Check parameters, connections and component. Replace as required
162	Air pressure switch error	Air pressure switch/Flue pressure switch does not close	1. Check flue path for obstructions. Unblock as required 2. Check connection/wiring and pressure switch. Replace as required. <b>Floor appliances (from 120 kW):</b> 3. Check air intake for obstructions. Unblock as required.
164	Flow/pressure switch, heating circuit error	No flow detected	Remove the air from the circuit; Update the parameter set. Check connection and switches in HC. Replace as required
166	Air pressure switch error	Air pressure switch does not open	Check connection and adjustments on air pressure switch. Replace as required.
170	Error water pressure sensor, primary side		Check connection and sensor. Replace as required.
171	Alarm contact 1 active		Correct the active fault
172	Alarm contact 2 active		
173	Alarm contact 3 active		
174	Alarm contact 4 active		
176	Water pressure 2 too high		Release the water to a suitable pressure.
177	Water pressure 2 too low		Top up the system with water to reach a suitable pressure.



Error code	Fault description	Explanation	Action(s)
178	Temperature limiter heating circuit 1		Allow the circuit to cool down and carry out reset; if the fault occurs several times inform AIC technical support.
179	Temperature limiter heating circuit 2		Allow the circuit to cool down and carry out reset; if the fault occurs several times inform AIC technical support.
183	Unit in parametrization mode		Wait until parametrization process is complete
193	Start prevention signal input	<p>Short circuit or Open circuit According to appliance model, can apply to the following :</p> <ul style="list-style-type: none"> <li>▶ air pressure switch</li> <li>▶ flue pressure switch</li> <li>▶ condensate level switch</li> <li>▶ burner plate temp. limit switch</li> <li>▶ Additional external max. temp limit switch</li> <li>▶ Additional external max. pressure limit switch</li> </ul>	<ol style="list-style-type: none"> <li>1. Check flue path for obstructions. Unblock as required</li> <li>2. Check connection/wiring and pressure switch. Replace as required.</li> </ol> <p><b>Floor appliances (120 to 280 kW):</b></p> <ol style="list-style-type: none"> <li>1. Check connection/wiring and condensate level switch. Replace as required</li> <li>2. Check connection/wiring and burner plate temp. limit switch. Replace as required</li> </ol> <p><b>Floor appliances &gt;300 kW</b> Same as 120 to 280 kW appliances and</p> <ol style="list-style-type: none"> <li>3. Also check additional external max temp limit switch and additional external max pressure limit switch and connection. Replace as required</li> </ol>
195	Maximum duration of the refill per charging exceeded		Check automatic refill system.
 <i>The use of an automatic refill system is not recommended</i>			
196	Maximum duration of the refill per week exceeded		Check automatic refill system.
 <i>The use of an automatic refill system is not recommended</i>			
209	Fault heating circuit		Check the heating circuit configuration. Reset to default parameters
216	Fault boiler		Check the heating circuit configuration. Reset to default parameters
217	Sensor error		Check connection and sensor. Replace as required.
218	Pressure supervision		Check system pressure.
243	Swimming pool sensor, error		Check connection and sensor. Replace as required.
260	Flow temperature 3, sensor error		Check connection and sensor. Replace as required.

## ADDITIONAL INFORMATION FOR THE INSTALLER

Error code	Fault description	Explanation	Action(s)
270	Temperature difference, heat exchanger too large		Check the heating system external hydraulic components.
317	Mains frequency outside permissible range		Check correct electric supply in boiler terminals.
320	DHW charging temperature, sensor error		Check connection and sensor. Replace as required.
321	DHW outlet temperature, sensor error		Check connection and sensor. Replace as required.
322	Water pressure 3 too high		Release the water to a suitable pressure.
323	Water pressure 3 too low		Top up the system with water to reach a suitable pressure.
324	Input BX, same sensors		Check configuration in parameters list
325	Input BX/extension module, same sensors		Check configuration in parameters list.
326	Input BX/mixing group, same sensors		Check configuration in parameters list.
327	Extension module, same function		Check configuration in parameters list.
328	Mixing group, same function		Check configuration in parameters list.
329	Extension module/mixing group same function		Check configuration in parameters list.
330	Sensor input BX1 without function		Connect temperature sensor in BX terminal
331	Sensor input BX2 without function		Connect temperature sensor in BX terminal
332	Sensor input BX3 without function		Connect temperature sensor in BX terminal
333	Sensor input BX4 without function		Connect temperature sensor in BX terminal
335	Sensor input BX21 without function		Connect temperature sensor in BX terminal
336	Sensor input BX22 without function		Connect temperature sensor in BX terminal
341	Sensor B6 missing	Solar sensor missing	Check parameters, connection and component.
349	Buffer storage tank return valve Y15 missing		Check connection of return valve Y15. Replace as required.
350	Buffer storage tank address error		Correct device address.
351	Primary controller/ system pump, address error		Correct device address.
352	Pressureless header, address error		Correct device address.
353	Sensor B10 missing	Common flow sensor missing	Check parameters, connection and component

Error code	Fault description	Explanation	Action(s)
371	Flow temperature heating circuit 3		Check the circuit for fault insulation and heat losses.
372	Temperature limiter heating circuit 3		Allow the circuit to cool down and carry out reset; if the fault occurs several times inform AIC technical support.
378	Internal repetition		Contact AIC technical support
382	Repetition speed		Contact AIC technical support
384	Extraneous light		Shut off gas supply and contact AIC technical support
385	Mains undervoltage		Check electric supply in boiler terminals
386	Fan speed tolerance		Check air supply
388	DHW sensor no function		Check connection and sensor. Replace as required.
391	Room controller 1		
392	Room controller 2		Check addresses and parameters
393	Room controller 3		
426	Feedback flue gas damper		Check the connection and component
427	Configuration flue gas damper		Check configuration parameters
429	Dynamic water pressure too high	Expansion tank is defective	Verify pump Replace expansion tank
430	Dynamic water pressure too low		Verify pump
431	Sensor primary heat exchanger		Check connection and sensor. Replace as required.
432	Function ground not connected		Check ground connection and install as required
433	Temperature primary heat exchanger too high		Check the heating system external hydraulic components.

## Performing Reset

There are two types of resets depending on the kind of error:

### 1. Reset interactive errors through the function.



- › Select “**Reset**” and press on rotary button.
- › The text changes to “**Confirm**”. Press on rotary button.
- › The page is automatically closed if the error has disappeared.

### 2. Reset locking errors through the Unlock button.

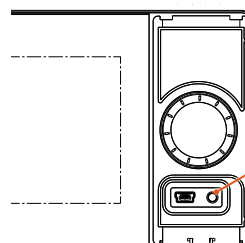

#### Locking error features:

- › Remain saved also after mains off.
  - › Unlocking is required even after the fault no longer is present.
  - › If error still persists, remove first the error.
- › Remove the side cover using the tip of a screwdriver.
  - › Depress the Unlock button (1) using a sharp object (e.g. pen point) for 0,4 to 10 seconds.
  - › The message “**! Reset**” appears on the screen.
  - › If the problem is still present, call your AIC representative.

## ADDITIONAL INFORMATION FOR THE INSTALLER

### Troubleshooting

Problem	Cause(s)	Solution(s)
Boiler does not start	No power supply	<ol style="list-style-type: none"> <li>1. Check that the power button is in ON position (pushed in and illuminated)</li> <li>2. Make sure the power supply cable is connected to the mains</li> <li>3. Check the external power supply box (circuit breaker) and reset it as required.</li> </ol>
Boiler display remains blank	No power supply	<ol style="list-style-type: none"> <li>1. Check wiring connection.</li> <li>2. Check wiring continuity.</li> <li>3. Replace wiring.</li> </ol>
	Main board fuse(s) blown	Replace blown fuse(s) on electronic board (T6 3AH 250V).
Circulating pump does not start	Pump power supply	<ol style="list-style-type: none"> <li>1. Check wiring connection.</li> <li>2. Check wiring continuity.</li> <li>3. Replace wiring.</li> </ol>
	Relay malfunction	<ol style="list-style-type: none"> <li>1. Check the relay.</li> <li>2. Replace the electronic board.</li> </ol>
	Pump malfunction	<ol style="list-style-type: none"> <li>1. Reset the pump.</li> <li>2. Check if there is voltage at the pump. If there is, replace the pump.</li> </ol>
Gas smell	Leak in gas circuit	<ol style="list-style-type: none"> <li>1. Check tightness of connections and circuit.</li> <li>2. Check that pressure measuring points are closed.</li> </ol>
Unburned gas smell	Leak in flue gas circuit	<ol style="list-style-type: none"> <li>1. Check tightness of connections.</li> <li>2. Check there are no obstructions in the flue system.</li> <li>3. Check the quality of combustion.</li> </ol>
	Wrong combustion settings	Check the values with a gas analyser and readjust as required.
	Combustion air circulation	Check that the air openings are not blocked.
	Burner and combustion chamber condition	Check if they are clean.
	Heat exchanger fire tubes are blocked	Check if condensate outlets are not obstructed. Clean as required.
Irregular combustion	Fan malfunction	<ol style="list-style-type: none"> <li>1. Check if fan is working.</li> <li>2. Check wiring connections</li> <li>3. Check wiring continuity</li> <li>4. Check if there is voltage at the fan. If there is, replace the fan.</li> <li>5. Verify signal cable connection</li> </ol>
	Wrong size of flue and/or combustion air ducts.	Check duct sizes and correct as required
Hard ignition	Wrong combustion settings	Check the values with a gas analyser and readjust as required.
	Ignition electrode malfunction	Check the condition and distance at stem tips (refer to Electrode Removal procedure)

Problem	Cause(s)	Solution(s)
Burner does not start after receiving signal from boiler controller	Gas valve malfunction	<ol style="list-style-type: none"> <li>1. Check wiring connections</li> <li>2. Check components</li> </ol>
	Fan malfunction	
	Ignition/ionization electrode malfunction	
Combustion chamber gets dirty	Wrong combustion settings	Check the values with a gas analyser and readjust as required.
Boiler does not reach working temperature	Boiler controller	<ol style="list-style-type: none"> <li>1. Adjust temperature setpoint.</li> <li>2. Check controller operation.</li> <li>3. Replace controller.</li> </ol>
	Poor heat transfer	Clean combustion chamber
	Insufficient burner power	Check combustion settings
	Dirty burner	Clean burner
	Wrong chimney pressure drop	Check chimney pressure drop
Temperature too high compared to setpoint	Boiler controller malfunction	<ol style="list-style-type: none"> <li>1. Check temperature setpoint.</li> <li>2. Check controller operation.</li> <li>3. Check position of temperature sensors.</li> </ol>
	Radiator valves closed	Open radiator valves
	Air in the system	Bleed the air present in the heating system
Heat exchanger reaches temperature setpoint but radiators are cold	Circulating pump malfunction	<ol style="list-style-type: none"> <li>1. Check if circulating pump is running</li> <li>2. Check pump wiring connection and continuity.</li> <li>3. Reset pump</li> <li>4. Check if there is voltage at the pump. If there is, replace the pump.</li> </ol>
Safety valve opens frequently	System safety valve	Check pressure rating of the safety valve (suitable to the system pressure).
	Pressure in the heating system	Check the pressure in the system (max. 6 bar).
	Expansion tank	Check the expansion tank size and operation.

## Maintenance Messages

Code	Meaning	Action
1	Number of burner hours run exceeded	<b>Contact Maintenance service</b>
2	Number of burner starts exceeded	
3	Maintenance interval exceeded	
5	Water pressure 1 heating circuit too low	<b>Fill the circuit to reach acceptable pressure.</b>
18	Water pressure 2 heating circuit too low (dropped below lower pressure limit 2)	

## ADDITIONAL INFORMATION FOR THE INSTALLER

### Installation Checklist

	Unit	Values/Comments
<b>General/heating system</b>		
Type of building/system		
Commercial purpose (Y/N) ?		
Year of manufacture		
Output of system	kW	
Heated surface	m <sup>2</sup>	
Number of heating circuits:		
• Floor heating		
• Radiators		
• Other		
Cascade (Y/N)? Number of appliances?		
<b>Water</b>		
Water hardness at start up	mol/m <sup>3</sup> or mg/l	
System volume	L	
Additive(s)/Antifreeze (Y/N)?		
• Type		
• Quantity	%	
<b>Gas</b>		
Type?		
Heating value	kWh/m <sup>3</sup>	
Gas pressure regulator installed (Y/N)? Type ?		
<b>Hydraulics</b>		
Heating circuit normal pressure	bar	
Air purged from the system (Y/N)?		
Safety valve installed (Y/N)? rating?	bar or kW	
Expansion tank(s) installed (Y/N)? Type(s) ?		
• Size?	L	
• Precharged pressure ?	bar	
• Number		

	Unit	Values/Comments
Plate heat exchanger in the system (Y/N)? Type?		
Low loss header in system (Y/N)? Type ?		
Number of mixers ?		
Buffer tank (Y/N)? Size?	L	
DHW tank (Y/N)? Type?	L	
Pump(s) (Y/N)? Type?		
<ul style="list-style-type: none"> <li>• In which circuit(s)</li> <li>• Chosen according to requirements for the appliance?</li> </ul>		
<b>Flue gas</b>		
Open or closed system?		
Dimensions of combustion air openings if closed system	cm <sup>2</sup>	
Material of flue piping		
Diameter and length of piping system	mm / m	
Chimney system engineered by?		
Calculated pressure drop, including maximum wind condition (<200 Pa)?	Pa	
Cascade (Y/N)?		
Back-flow preventer or non-return valve installed (Y/N)? Type?		
<b>Condensates</b>		
Condensate discharge slope	° or cm/m	
Condensate trap filled (Y/N)?		
Neutralisation system installed (Y/N)? Type ?		
Condensate pump installed (Y/N)?		
Condensate pump control line connected (Y/N)?		







# ADDITIONAL INFORMATION FOR THE INSTALLER

## Water Parameters - Log Sheet

Water Filling Date	Water Top-up Date	Water Quality	Water Treatment	Remarks	Name & signature



**EU Declaration of Conformity No. 2019/03EU/03**

Product identification: **Wall-hung Condensing Boiler**

Nesta Chrome N 24 WH, Nesta Chrome N 32 WH, Nesta Chrome N 38 WH, Nesta Chrome N 45 WH, Nesta Chrome N 60 WH, Nesta Chrome N 80 WH, Nesta Chrome N 100 WH, Nesta Chrome N 115 WH, Nesta Chrome N 120 WH, Nesta Chrome N 150 WH.

Manufacturer: AIC EUROPE BV  
Graafschap Hornelaan 163A  
NL-6001 AC Weert  
The Netherlands

This declaration of conformity is issued under the sole responsibility of the manufacturer. The object of the declaration described above is in conformity with the relevant Union harmonization legislation:

- GAR** Gas Appliance Regulation (EU) 2016/426
- BED** Boiler Efficiency Directive 92/42/EEC
- ErP** Energy Related Products Directive 2009/125/EC
- ELD** Energy Labelling Directive 2010/30/EU
- LVD** Low Voltage Directive 2014/35/EU
- EMC** Electromagnetic Compatibility Directive 2014/30/EU
- RoHS** Restriction of Hazardous Substances Directive 2011/65/EU

Conformity assessment procedure:	<b>Module B + D</b>
Name, address, identification number of the notified body:	<b>Module B: Kiwa Nederland B.V. Apeldoorn, Netherlands, ID no. 0063</b>
Number EU Type Test Examination Certificate / Validity Date: Product-ID-Number:	<b>19GR0382/06 / 19BE0060/03 23.06.2032 / - 0063CU3550</b>
Name, address, identification number of the notified body:	<b>Module D: SZUTEST Engineering Test Institute, Brno, Czech Republic, ID no. 1015</b>

The conformity of the product described above with the provisions of the applied Directives is demonstrated by compliance with the following standards / regulations:

EN 15502-1:2021	EN 55014-1:2021
EN 15502-2-1:2012+A1:2016	EN 55014-2:2021
EN 60335-1:2012+A1:2019+A2:2019+A11:2014+A13:2017+A14:2019	EN 61000-3-2:2019
EN 60335-2-102:2016	EN 61000-3-3:2013

Signed for and on behalf of AIC EUROPE BV  
Weert, 06.07.2022

Cyril Bongaerts,  
Research & Development Director

AIC Europe B.V.  
Graafschap Hornelaan 163A  
NL-6001 AC Weert  
The Netherlands

[www.myaic.eu](http://www.myaic.eu)